

# Perimeter protection



## SISMA CP 50 installation technical manual

*Version 0.1.6*

*Buried system of underground type*





---

## Premise

The present document is regularly updated because of the continuous technological development of the product and the constant flow of information acquired by Dea Security's Technicians. Therefore, it is absolutely necessary to keep in touch with Dea Security's technical department and ask for the most updated manual.

Despite the information contained in the present document may lead to a good knowledge of the product, for a correct designing of a plant, an inspection on the spot must be executed by DEA SECURITY's skilled technicians. Thanks to their deep knowledge of the product and their experience coming from many successful installations carried out, they are the only ones who can endorse the realization of the plant.

As a further guarantee to a perfect execution of a plant, DEA SECURITY directly sends a skilled technician of its own, in the quality of supervisor during the installation, the connection and the test of a system.

Have a good job.

## Index

1 Introduction.....	3
2 Product usage evaluations.....	3
3 Draw up a project for the installation of a SISMA CP 50 system.....	4
3.1 String route determination.....	4
3.2 Alarm zone division.....	7
3.3 Processing board dislocation.....	10
3.4 Initial string, final string and following strings junction.....	12
3.5 Necessary resources.....	13
4 Installation procedures of SISMA CP 50 system.....	14
4.1 The features of the excavation.....	14
4.1.1 Ground with lawn surface.....	14
4.1.2 Ground covered with self-lockings or asphalt.....	15
4.2 Calculated lengths verification.....	16
4.3 Sensor laying into the excavation.....	17
4.4 Precautions for a correct usage of the cable.....	18
4.5 Canalizations, CV-SMCP50 cable laying.....	19
4.6 Electric connections of the string.....	21
4.6.1 Initial string junction.....	22
4.6.2 Intermediate String Junction.....	23
4.6.3 End of Line Termination.....	24
5 Excavation closing.....	25
5.1 Lawn surface.....	26
5.2 Ground covered with asphalt, self-lockings or stones.....	28
6 Electric connections of the processing board Z1.....	30
7 Electric connections of the processing board Z2.....	32
8 Sensitivity calibration.....	33
9 Perturbing elements and preventive actions.....	34
9.1 Plants or pilings.....	34
9.2 Roads and streets.....	36
9.3 Buildings.....	37
9.4 Irrigation, fire-fighting and aqueduct pipes.....	38
9.4.1 Pipes perpendicular to the string.....	38
9.4.2 Pipe parallel to the string.....	41
9.5 Pumps.....	42
9.6 Drain trunk-line.....	43
9.7 Unstable structures.....	46
10 Maintenance.....	47
11 Assistance.....	47



## 1 Introduction

This manual aims at helping technical installers to:

- evaluate and find the best usage solutions of the product;
- draw up a project for the installation of a SISMA CP 50 system;
- carry out the installation procedures of this system;
- test and calibrate this system.

## 2 Product usage evaluations

SISMA CP 50 system can be installed in grounds covered with grass, gravel, asphalt, self-lockings or tiles and in all those sites where no rigid structure, for example concrete, is situated between the system and the surface. Since each type of surface has a different seismic behaviour, it is very important to evaluate the operative environment to have a rough estimate of the strings to be installed. In case of mixed surfaces composed of concrete paths, low walls, metal fences or rigid metal structures, one has to consider the possibility of integrating SISMA CP 50 system with other DEA SECURITY's systems such as SISMA CA, SERIR 50 or TORSUS 50.

The sensors work at a depth of 60 cm, in an environment minimally affected by external climatic conditions and perfectly compatible with normal gardening job. This position implies an excavation of 60 cm in width and 60 cm in depth along the whole protection line.

The route of the strings must not be rectilinear to avoid identification and each string has to be no longer than 50 m.

When evaluating a string route, one has to keep a security distance from disturbing elements, such as trees, pilings, pergolas and so on which can swing under the action of the wind and cause seismic waves in the ground.

Besides visible disturbing elements, one has to take into account the disturbances coming from underground, caused by irrigation pipes and pumps, aqueduct and fire-fighting pipes.

Moreover, one has to consider the necessity of identifying small alarm sectors in which only dedicated strings have to be used.

When protecting big perimeters, it is possible to carry out a centralized management of the system by using DEA NET or IP network, which, through the usage of a normal cable FTP cat. 5, permits transmitting data from peripheral cabinets, containing single SISMA CP 50 boards, to the control panel. A SC-DN-CTRL OR SC-DN-ETHRPT will have to be installed inside the control panel, to proceed to the management of all the peripheral SISMA CP 50 boards.

As regards the laying times of a SISMA CP 50 system, once the project has been made, it is possible to sense up to 150 m of perimeter a day with two technical installers, two hand labourers and a mechanical excavator.

### 3 Draw up a project for the installation of a SISMA CP 50 system

To draw up an accurate project, it is necessary to execute an adequate inspection on the spot to deeply evaluate the client's needs, the types of ground and the presence of disturbing elements.

Here you are some definitions to permit a correct understanding of the contents of this manual:

- *Protection line*, that is the route controlled through a SISMA CP system. It is the set of all strings in any kind of soil they are situated.
- *Alarm zone*, that is a section of homogeneous ground with a maximum length of 50 m, controlled by SN-SMCP50 seismic sensors set in line every 90 cm and connected to a SISMA CP 50 processing board.

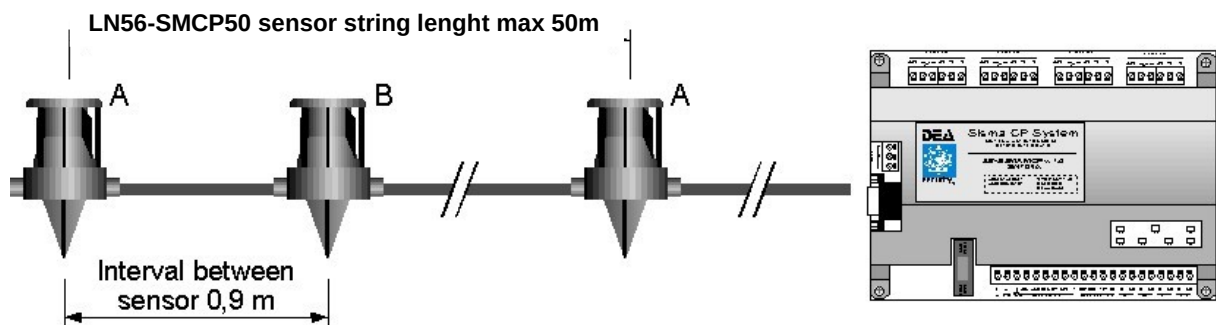

A SISMA alarm zone can be composed of 12, 24, 56 sensors for a perimeter protection of 10m, 30m and 50m. These sensors alternate every 90 cm to operate in AND mode in the same detection area.

#### 3.1 String route determination

When designing and making the inspection on the spot, to determine the route and the length of SISMA CP 50 strings, it is necessary to:

- take into account the presence of disturbing elements;
- not to follow a rectilinear direction;
- consider different types of surface.
- *Disturbing elements*. SISMA CP 50 system is sensitive to very low pressure waves, normally originated by a person passing on the ground. If near the detection line there are moving bodies of a certain consistency, vibrations and consequently improper alarms can occur.



*Therefore it is extremely important to carry out an inspection on the spot to evaluate the presence of disturbing elements.*

Despite the inspection on the spot, it is not possible to notice with certainty the presence and the entity of disturbing elements such as pressure pipes and roots, which are visible only when digging the excavation. Thus without a detailed map showing the position of underground pipes, it is necessary to use LN-SMCP50 strings to cover a perimeter at least 10% bigger than the length of the route calculated, so as to execute small route deviations during the sensor laying.

The suggested distances from disturbing elements are shown in the following table:

<b>DISTURBANCE</b>	<b>DISTANCE (metres)</b>
Plants or pilings	3~4
Roads and streets	5
Heavy traffic roads	10
Railways	50
Buildings	5
Irrigation pipes	1
Irrigation pumps	2
Acqueduct pipes	1
Fire-fighting system pipes	1
Unstable structures	1

If a security distance cannot be kept, it is possible to reduce the above distances through the usage of some protection preventive works, which will be analyzed in paragraph 9 on page 34.



*If in the determination of the route the suggested distances are kept, no further protection preventive action is necessary.*

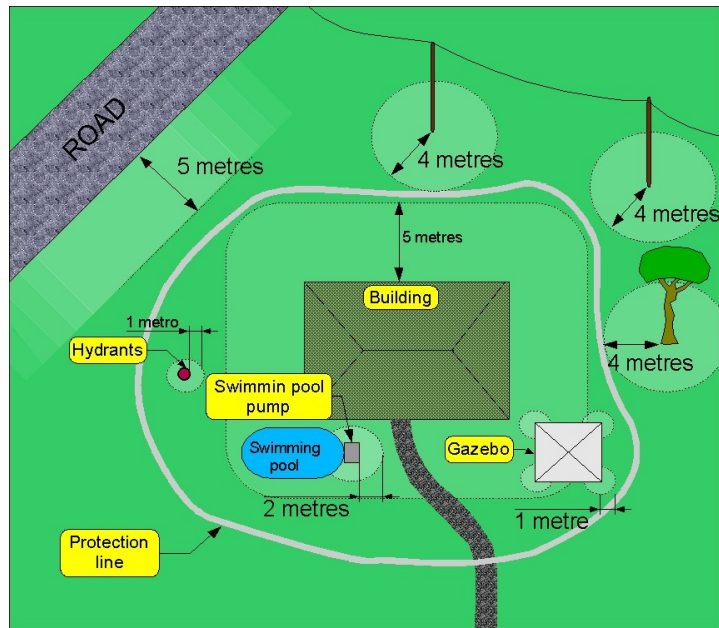

- *Not to follow a rectilinear direction.* When choosing a route, one has not to follow a rectilinear or too geometrical direction, but an accidental one, so as to make the interception of the protection line difficult.
- *Different types of surface.* If the protection line is crossed by different types of surfaces, the best thing to do would be trying to minimize the changes of surface, since each type of ground must have its own string with different sensitivity levels, with a consequent increase of processing boards and therefore costs. In the following picture an example of route based on these conditions is shown.



*In case one has to cross short sections of different surfaces in one zone, please contact DEA SECURITY.*

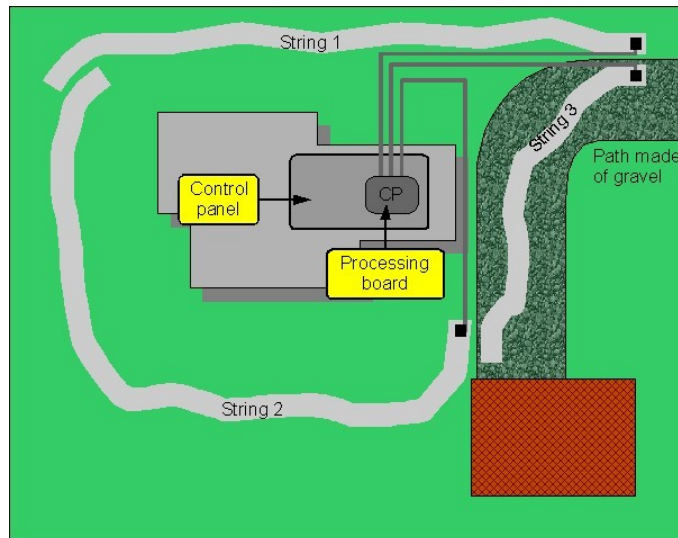

## 3.2 Alarm zone division

This paragraph concerns the necessity of dividing the protection line into alarm zones according to SISMA CP 50 system capabilities, the environment in which it works and the operative necessities of the alarm system. Therefore we can say that the strings division is carried out according to 3 main factors:

- String length
- Type of ground
- Easy identification of the alarm sector

Here you are a detailed analysis of the above factors:

- **String length.** The maximum length of a SISMA CP string is 50 m, corresponding to 56 sensors set at 90 cm one from another. Therefore if a protection line with a homogeneous surface is greater than 50 m, it is necessary to subdivide it into alarm zones with a length equal or inferior to the maximum one.
- **Type of ground.** The type of ground can influence the detection capability of the sensor, therefore each sensor string must be laid in the same type of soil, since each alarm zone has its own calibration and therefore cannot be composed of different ground sectors. For example the calibration carried out in a lawn soil is not suitable for an asphalted ground. Thus different grounds must be managed with different strings even if it is a question of few metres.

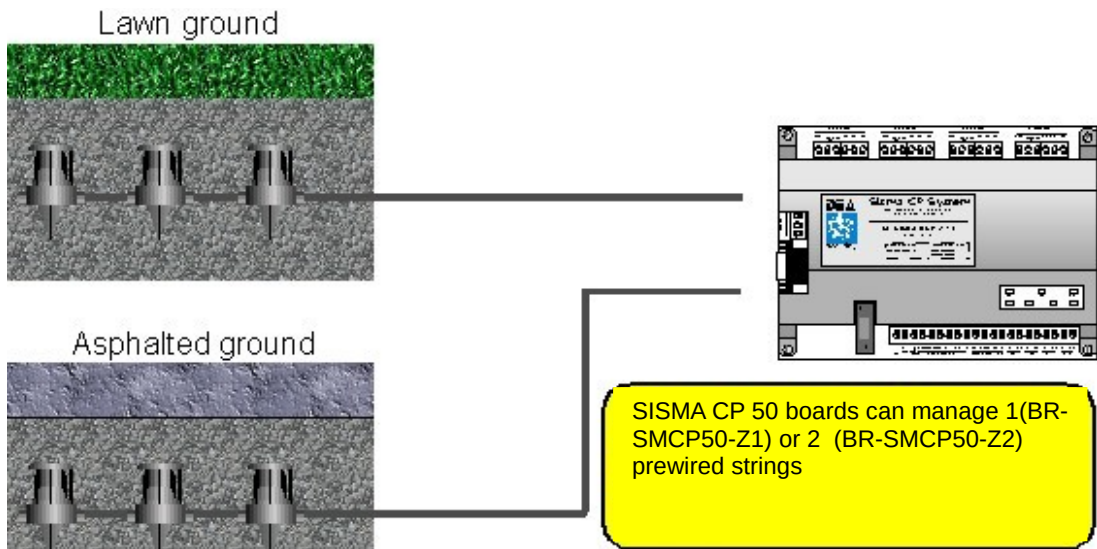
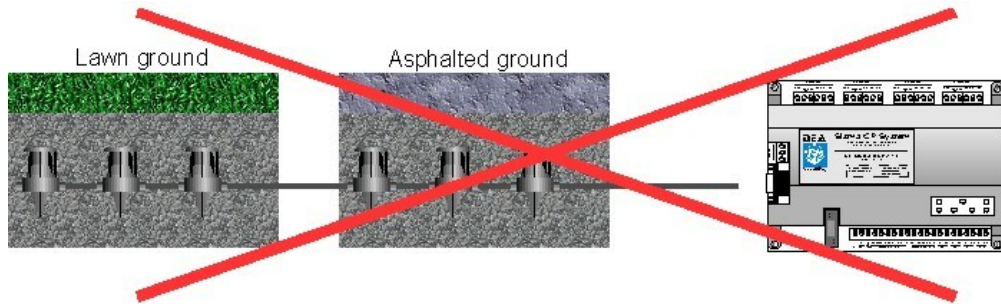

- *Easy identification of the alarm sector.* In particularly dangerous sites, to make the identification of the alarm sector easier, it could be necessary a subdivision of the controlled perimeter into many small zones, so as to have a more accurate detection detail for each string.

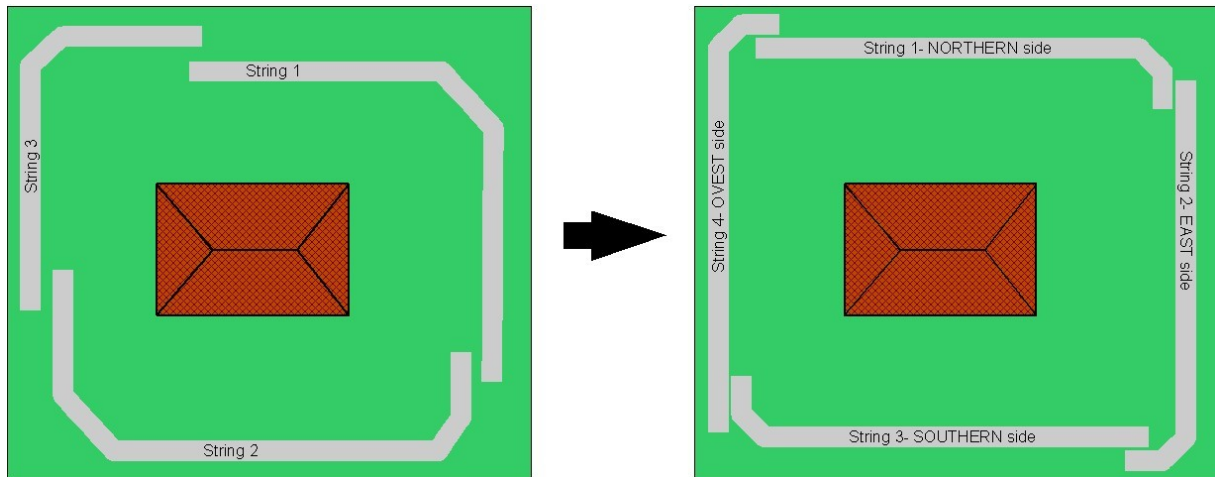

### 3.3 Processing board dislocation

SISMA CP 50 processing board can be positioned inside the control panel if this is situated within 150 m from the beginning of the string, or in special outdoor waterproof cabinets (peripheral cabinets) to be set near the sensor strings. The second solution, necessary for big perimeters, minimizes the quantity of cable to connect the sensor strings to the processing boards.

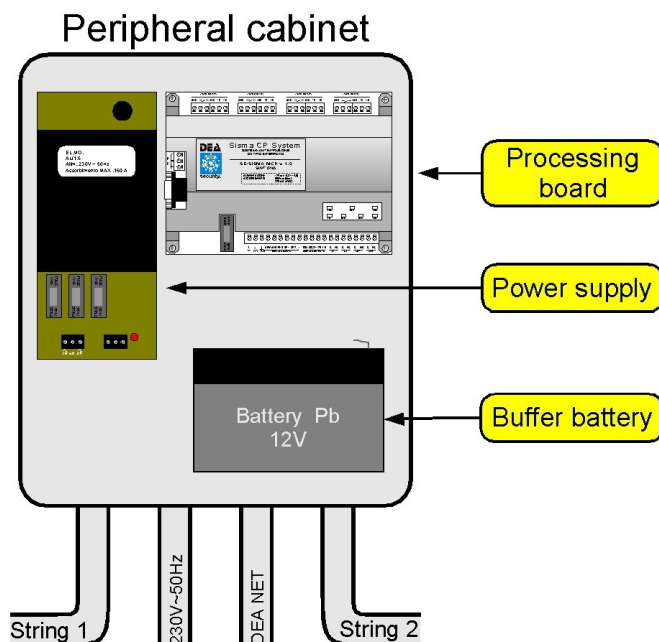

The connection between the peripheral cabinets and the control panel can occur through DEA NET or IP network, which permits a centralized management of the system, or through satellites or expansion boards of the control panel.

The peripheral cabinet will have to be composed of a waterproof polyester cabinet, for example an IP65 model, with an antitamper protection device (tamper). This cabinet will contain the processing board, a stabilized linear power supply and an emergency buffer battery. From the control panel, the power supply (230 V) and the data transmission cable (type FTP if DEA NET is used) will depart, each one with its own canalization. In addition, if the cabinet is installed under climatic conditions which would make the processing board work at a temperature out of the optimum range, it is necessary to air condition the cabinet, by installing inside it a heater with thermostat and/or a cooling fan with thermostat.



*The maximum length of CV-SMCP50 cable is of 150 m. Therefore, if the control panel is situated at more than 150 m, it is necessary to use the peripheral cabinets.*

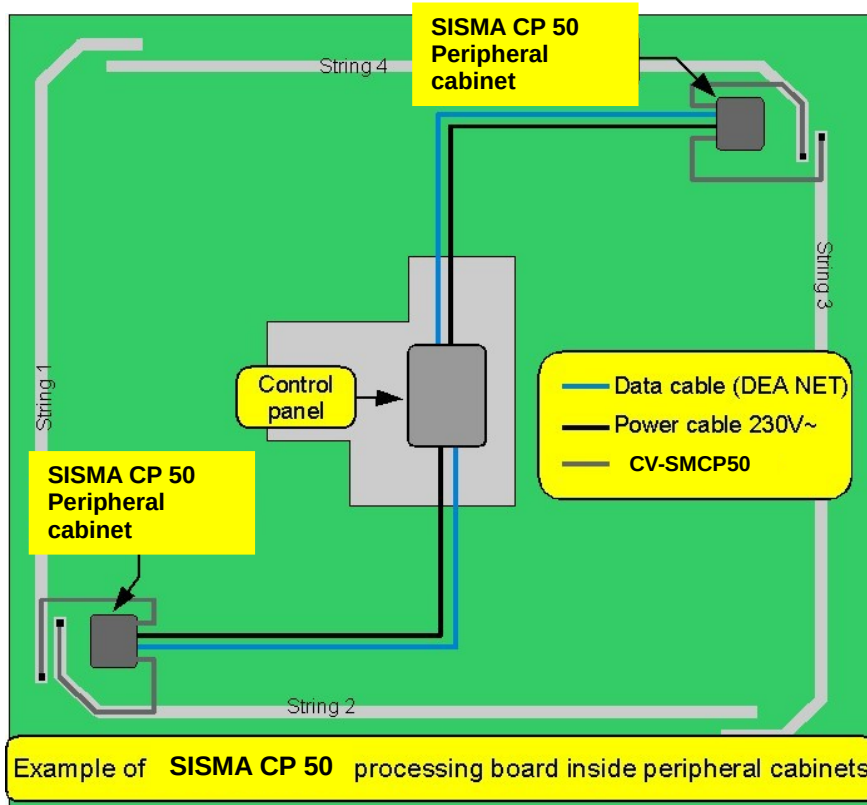
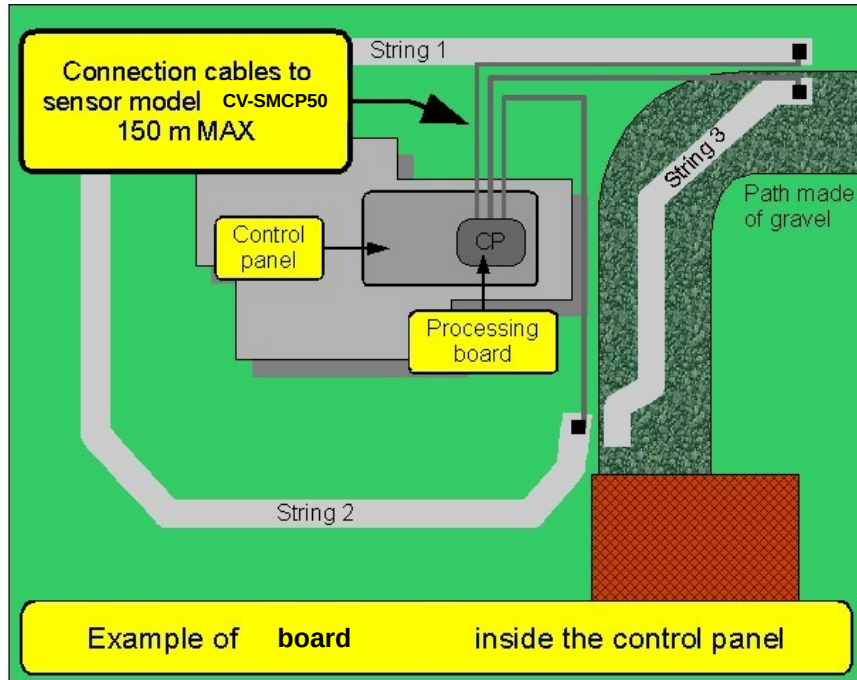

### 3.4 Initial string, final string and following strings junction

When drawing up a project for the installation of a SISMA CP 50 system, there are some rules regarding the beginning of the string, the end of the string and the junction of the two following strings :

- *Beginning and end of the string.* When starting or ending a string near a rigid obstacle, it is necessary to pay attention to the sensors laying. Examples of rigid obstacles can be the walls of a building, the boundary walls, the pavements and so on. The beginning or the end must be L-shaped, with a string section of at least 2 sensors which is parallel to the obstacle at a distance of about 50 cm.

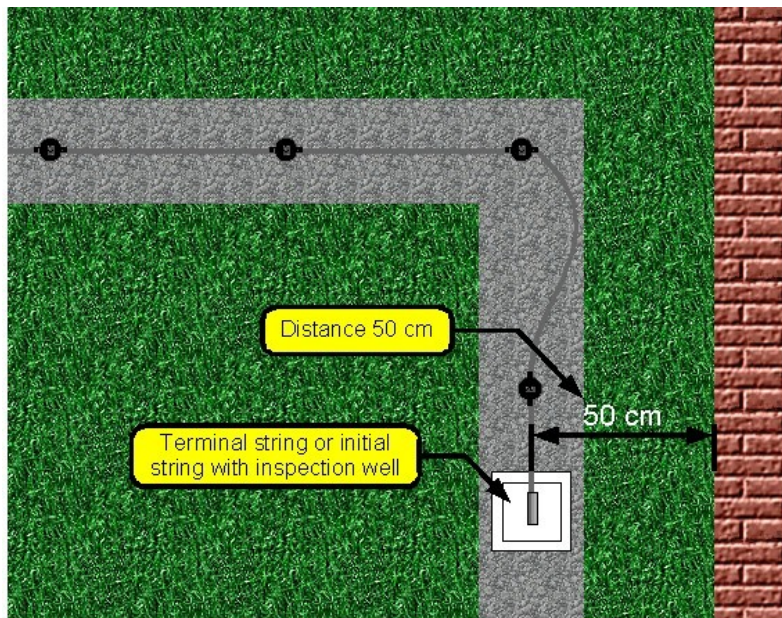

- *Following strings junction on the same type of surface.* If a protection line with a sequence of more than one sensor string must be realized, it is necessary to execute a small superimposition between a string and the following one. In this case a supplementary length of the string of about 1.5 m must be calculated.

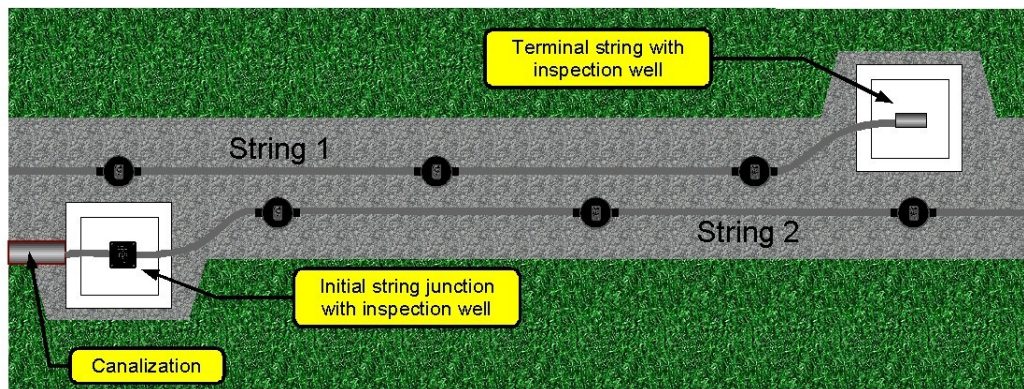

- **Following strings junction on different types of surface.** In case the protection line runs on different types of surface, the two following strings must meet with an L direction, as in the case of the beginning and end of the string. The two Ls will have to be positioned at a distance of 0.5 m, so as to have no gap in the protection line. The supplementary length to be calculated even in this case is about 1.5 m.

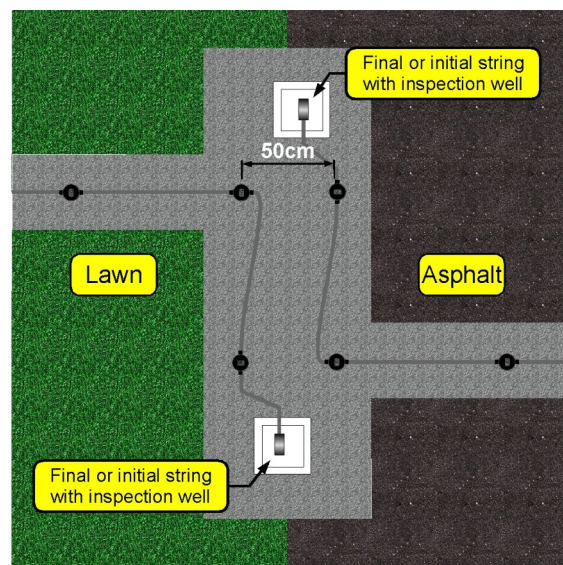
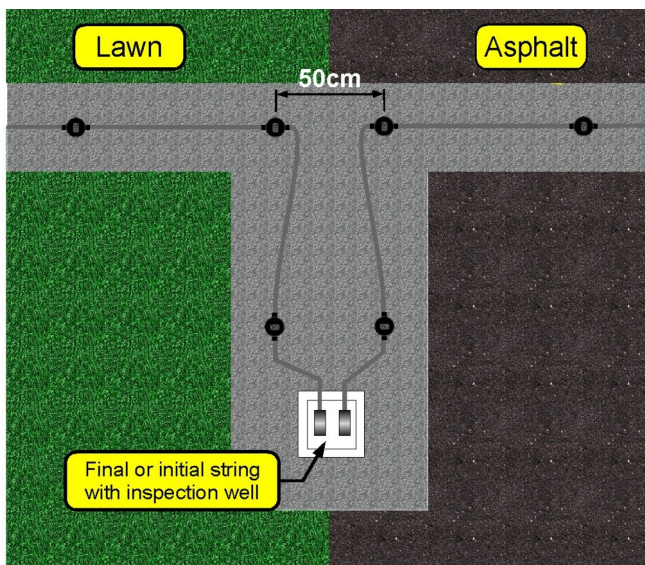

### 3.5 Necessary resources

For the installation of a SISMA CP 50 system, it is necessary the presence of two technical installers, who will carry out the laying of the sensors, the electric connections, the sealing of the junctions and of the terminal strings. In addition, at least two hand labourers with an excavating machine and various tools for the excavation and the coverage of it must be present.

It is also necessary to have the following accessory material in the yard:

- *Sand* to protect the sensors and the cables during the filling up of the excavation for about 1 cubic metre every 50 sensors;
- *Canalizations*, to be laid together with the sensor strings for the passage of CV-SMCP50 cable from the beginning of the string to the processing board.



*It is advisable to lay the canalization along the whole excavation, in case it is necessary to upgrade the system in the future, without opening the excavation.*

- *Wells*, for electric connections of beginning and end of string along the protection line. Wells of 30 x 30 cm for electric usage are suggested.



*The use of inspection wells is necessary since the junctions and the string terminals are executed on the spot during the laying phase, sometimes under very difficult conditions. Therefore, it is possible that wrong connections of some of the conductors are realized; for this reason, it is necessary that the junctions and the terminals can be inspectionable, so as to easily check the connections state and to be able to execute new connections.*

## 4 Installation procedures of SISMA CP 50 system

This chapter deals with:

- the features of the excavation;
- the calculated lengths verification;
- possible string variations;
- the laying of the sensors into the excavation.

The installation procedures of a SISMA CP 50 system must start only when the laying ground is on level and well beaten. In fact if after the installation of a SISMA CP 50 system the ground quotas were changed, the system would work out of the functioning target. In case of works carried out in depth, the string can be physically damaged or the sensors can be moved.

### 4.1 The features of the excavation

The excavation for the installation of a LN-SMCP50 must be executed on two types of ground:

1. Lawn soil (gardens and parks)
2. Ground covered with self-lockings or asphalt (yards and carriage ways).

In any case the excavation must be executed only when the ground in question is on level and well beaten.



*In any case the excavation must be executed only when the ground in question is on level and beaten.*

#### 4.1.1 Ground with lawn surface

The excavation for LN-SMCP50 sensor string must have a minimum depth of 60 cm and a width of about 60 cm.

It can be recovered with the ground taken off during the opening of the excavation, depriving it of stones which could damage the sensors. For more information about the closing of the excavation see paragraph 5.1 on page 26.

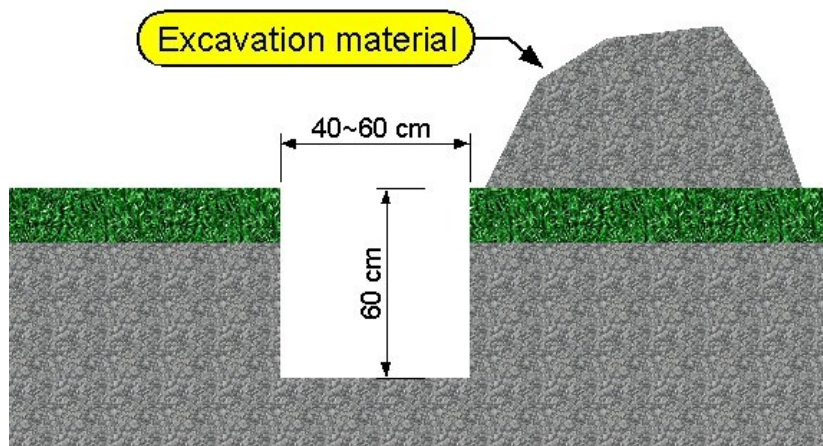

#### 4.1.2 Ground covered with self-lockings or asphalt

The excavation for LN-SMCP50 sensor string must have a minimum depth of 60 cm and a width of 60cm.

Differently from lawn surface, the ground with self-lockings or asphalt cannot be filled with the taken off material because it is rich in stones, but with quarry stabilizer. The stabilizer gives the ground the necessary solidity to bear the transit of vehicles, avoiding the damage of the sensors. For more information about the closing of the excavation, see paragraph 5.2 on page 28.

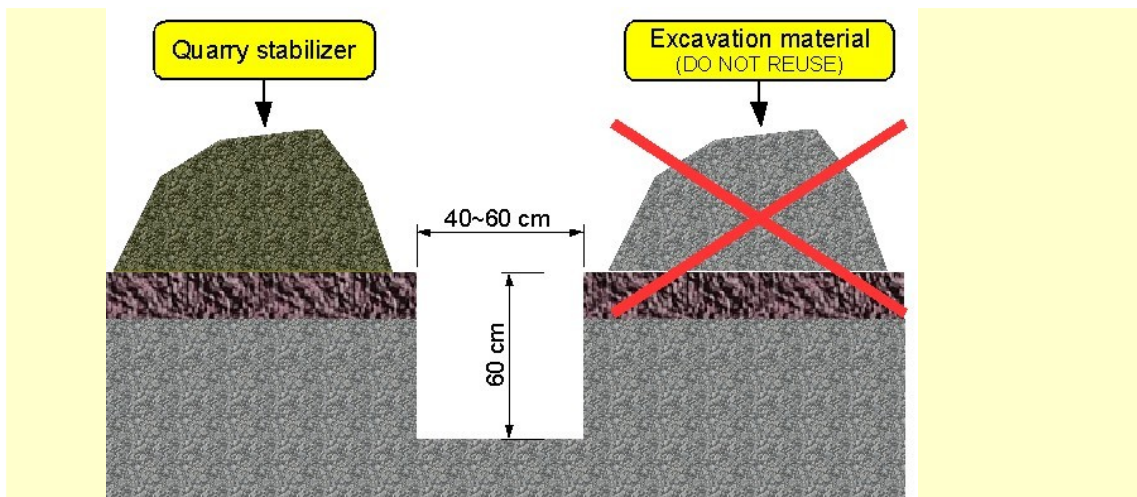

## 4.2 Calculated lengths verification

Once the excavation has been opened, it is also possible to verify the presence of underground obstacles which were not foreseen. It is often possible to keep the security distances from disturbing elements suggested in paragraph 3.1 on page 4 by simply executing some deviations, with consequent increase or decrease of the length of the protection line.



*It is a good rule to use a sensor string on average 10% longer than the designed route, since possible underground obstacles not foreseen and visible only when opening the excavation must be avoided with a route deviation.*

After verifying the presence of possible obstacles, lay the sensor string on one side of the excavation paying particular attention to the position of the sensors, which must be at 90 cm one from the other, so as to verify the conformity of the length. Three cases can occur:

- The string is perfectly suitable for the excavation;
- The string is longer than it;
- The string is shorter than it.

In the first case you have to proceed to the following working phase, that is the laying of the sensors into the excavation. In the other two case we have:

- *The string longer than the designed route.* If we had a sensor string longer than the excavation, it would be possible to set the sensors at less than 90 cm one from another (minimum 80 cm, all the sensors at the same distance) and make an L-shaped end of string longer; if we had to cross another string, to continue the protection line it would be possible to increase the superimposition of the two strings (please refer to paragraph 3.4 on page 12).
- *String shorter than the designed route:* In case of a sensor string shorter than the route planned, it is possible to lengthen it with a supplementary string by making a junction. Be careful not to exceed the limit of 50 sensors for each string.



*The lengthening of a string can be carried out provided that it does not exceed the number of 50 sensors all together. Please keep an alternation between A type sensors and B type sensors, which can be distinguished through a sticker*

on the sensor housing. The presence of an inspection well is necessary on the junction point.

For the execution of the junction, please refer to paragraph 4.6.1 on page 22.

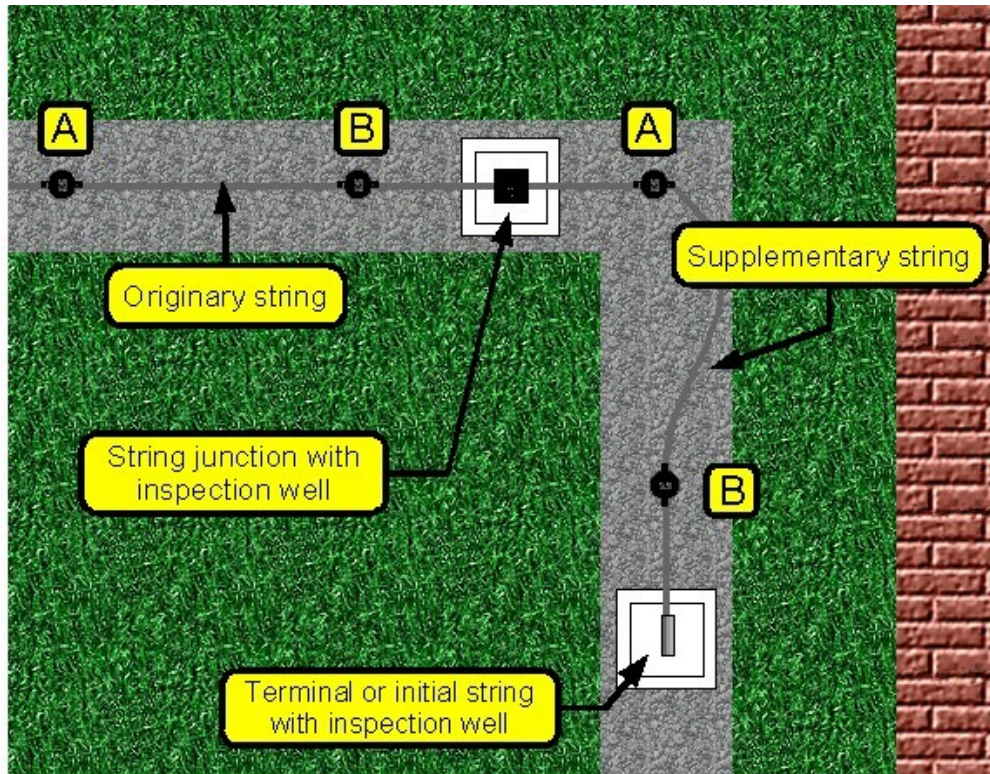

### 4.3 Sensor laying into the excavation

After laying the lengths of the strings and laying them along the excavation, you have to proceed to the definitive laying of the sensors. During this phase, handle the sensors with care, forcing only the cables input sleeves. The operative sequence is the following:

1. After laying the string into the excavation, set the sensors to the bottom, in a vertical position.
2. Set the sensors at about 90 cm one from another.
3. Insert the tip of the sensors into the compact ground.





*Handle the sensors with care, forcing only the cables input sleeves.*

The sensors connection cables are about 1.20 m longer to permit avoiding backs or small obstacles.

Once laid the strings, it is advisable to film or take a picture of the excavation still opened and make a diagram containing measures relative to some reference points.



*File films, pictures and diagrams in order to permit future interventions on the system in case of damages to the strings or as a reference for the client in case he has to have some gardening or building works done.*

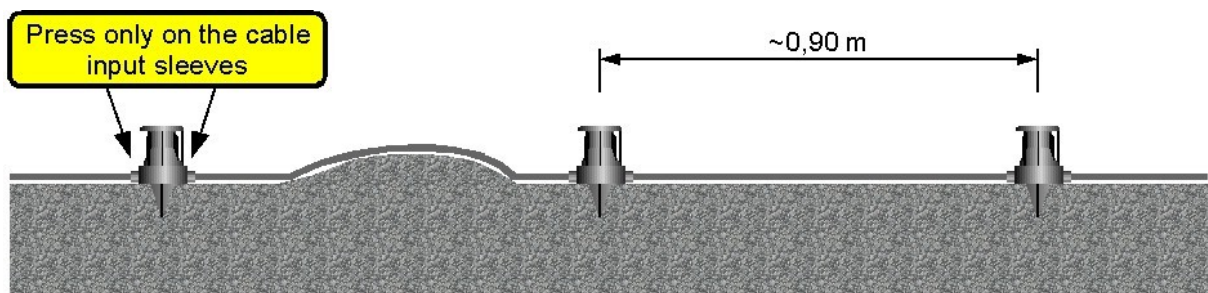

## 4.4 Precautions for a correct usage of the cable

When laying SISMA CP 50 system, it is necessary to prevent the ends of the string cables from getting in contact with water or excessive humidity, since water would be absorbed via capillar by the cable, provoking oxidation of the cable and possible future problems in the electric connections.

The same problem occurs if a long time goes by between the sensor laying and the execution of the electric connections and of the treatment with epoxy.



*Please protect the ends of the cables if you do not immediately proceed to the electric connections and the treatment with epoxy.*

In case the cable receives excessive humidity or it has not been immediately treated with epoxy after the laying, it is necessary to prevent the humidity from causing oxidation problems by cutting away the last sensor of the string, so as to stop the increase of humidity via capillar.



*In case the extremity of the cable receives humidity or it is not immediately treated with epoxy, it is necessary to cut the last sensor of the string before proceeding to the electric connections and the treatment with epoxy.*

Further precautions must be used with the extension cable CV-SMCP50, since the humidity would compromise the correct functioning of the cable even for many metres.



*Keep CV-SMCP50 cable in a dry place until you need to use it and provided that it is treated with epoxy as soon as possible.*

## 4.5 Canalizations, CV-SMCP50 cable laying

In case you need to lay ,together with the sensors, a canalization for electric cables or for the extension of the beginning of the string with CV-SMCP50 cable, it is necessary that this canalization does not get in contact with the sensors of SISMA CP 50 system.

The reason is that the canalization would become a vehicle of vibrations and if a small animal entered it it could cause improper alarms.



*The canalizations must not touch the sensors of the string.*



Examples of sensor laying

## 4.6 Electric connections of the string

The electric connections of the string are necessary to extend the cable of the string so as to arrive at the SISMA CP 50 processing board (string junction/termination), repair the damaged cable, lengthen a short string and execute a string terminal. In any case one has to follow these general rules:

- All the connections must be soft soldered and sealed with two component epoxy for electric connections, with RP-100. A kit is sufficient for sealing 1JBX-SMCP50-ILT, JBX-SMCP50 or TBX-SMCP50 kit.



*Do not use sylicon for sealing electric connections. Only use RP-100 epoxy which is specially studied for this application.*

The sylicon contains solvents which provoke a rapid oxidation and corrosion of the copper conductors present in the strings cables, therefore its usage is forbidden for sealing the electric connections.

- Before sealing the connections with epoxy it is absolutely necessary to check the connections and the insulations.
- All the connections must be situated inside inspection wells and the connection cables between the strings and the processing boards must be put inside pipes.

## 4.6.1 Initial string junction

To connect the sensor strings, it is exclusively used *Dea Security cable mod. CV-SMCP50*. The connections must be soldered and treated with epoxy RP-100.

For the initial string junction JBX-SMCP50-ILT kit must be used.



*The length of the connection cable between the beginning of the string and the processing board must be 150m maximum.*

The procedure for the connection is the following one :

1. Place the pile shoe into the ground in a vertical position
2. Insert the junction case into the pile shoe with the cables upwards
3. Prepare the polyurethane resin as shown on its package
4. Pour the resin inside the case using the cover holes
5. Wait for the resin polymerization (at least 40 minutes at 5°C or at least 25 minutes at 25°C).
6. Turn the junction case upside down and insert it into the pile shoe with cables downwards
7. Pour with RP-100 kit

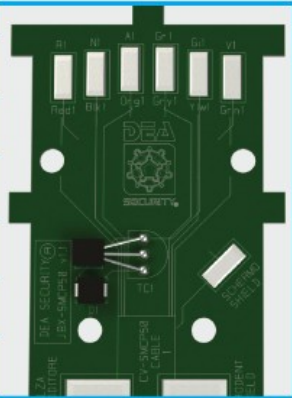
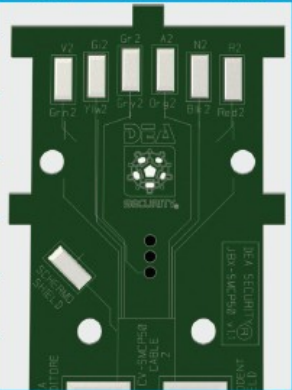
	PCB SILKSCREEN	COLORS	
INPUT (FROM SENSOR)	R1 (Red1)	RED IN	
	N1 (Blk1)	BLACK IN	
	A1 (Org1)	ORANGE IN	
	Gr1 (Gry1)	GREY IN	
	Gi1 (Ylw1)	YELLOW IN	
	V1 (Gm1)	GREEN IN	
OUTPUT (TO SENSOR)	PCB SILKSCREEN	COLORS	
	V2 (Gm2)	GREEN OUT	
	Gi2 (Ylw2)	YELLOW OUT	
	Gr2 (Gry2)	GREY OUT	
	A2 (Org2)	ORANGE OUT	
	N2 (Blk2)	BLACK OUT	
R2 (Red2)	RED OUT		

## 4.6.2 Intermediate String Junction

A JBX-SMCP50 Kit must be used for string reparation, extension and bypass.

Follow this procedure :

1. Place the pile shoe into the ground in a vertical position.
2. Insert the junction case into the pile shoe with the cables upwards.
3. Prepare the polyurethane resin as shown on its package
4. Pour the resin inside the case using the cover holes.
5. Wait for the resin polymerization (at least 40 minutes at 5°C or at least 25 minutes at 25°C).
6. Turn the junction case upside down and insert it into the pile shoe with cables downwards
7. Pour with RP-100 kit

<b>INGRESSO (FROM SENSOR)</b>	<b>SERIGRAFIA CB</b>	<b>COLORI</b>	
	R1 (Red1)	ROSSO IN	
	N1 (Blk1)	NERO IN	
	A1 (Org1)	ARANCIONE IN	
	Gr1 (Gry1)	GRIGIO IN	
	Gi1 (Ylw1)	GIALLO IN	
V1 (Gm1)	VERDE IN		
<b>USCITA ()</b>	<b>SERIGRAFIA PCB</b>	<b>COLORI</b>	
	V2 (Gm2)	VERDE OUT	
	Gi2 (Ylw2)	GIALLO OUT	
	Gr2 (Gry2)	GRIGIO OUT	
	A2 (Org2)	ARANCIONE OUT	
	N2 (Blk2)	NERO OUT	
R2 (Red2)	ROSSO OUT		

### 4.6.3 End of Line Termination

For the termination of the SISMA CP 50 string TBX-SMCP50 kit must be used.

Follow this procedure:

1. Place the pile shoe into the ground in a vertical position
2. Insert the junction case into the pile shoe with the cables upwards
3. Prepare the polyurethane resin as shown on its package.
4. Pour the resin inside the case using the cover holes
5. Wait for the resin polymerization (at least 40 minutes at 5°C or at least 25 minutes at 25°C).
6. Turn the junction case upside down and insert it into the pile shoe with cables downwards.
7. Pour with RP-100 kit

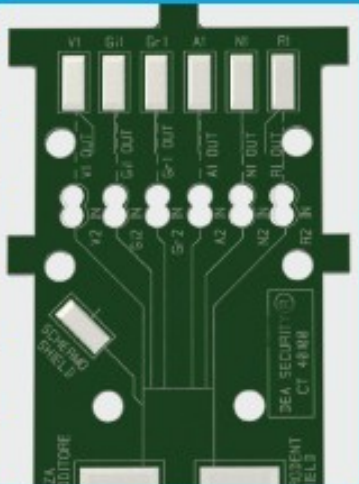
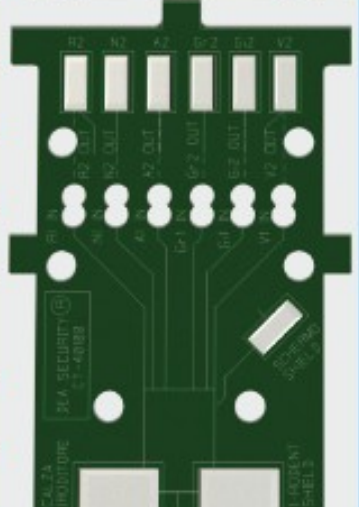
<b>INGRESSO (FROM SENSOR)</b>	<b>SERIGRAFIA CB</b>	<b>COLORI</b>	
	R1 (Red1)	ROSSO IN	
	N1 (Blk1)	NERO IN	
	A1 (Org1)	ARANCIONE IN	
	Gr1 (Gry1)	GRIGIO IN	
	Gi1 (Ylw1)	GIALLO IN	
V1 (Gm1)	VERDE IN		
<b>USCITA 0</b>	<b>SERIGRAFIA PCB</b>	<b>COLORI</b>	
	V2 (Gm2)	VERDE OUT	
	Gi2 (Ylw2)	GIALLO OUT	
	Gr2 (Gry2)	GRIGIO OUT	
	A2 (Org2)	ARANCIONE OUT	
	N2 (Blk2)	NERO OUT	
R2 (Red2)	ROSSO OUT		

## 5 Excavation closing

The filling operations must be carried out only when the epoxy used in the terminals and in the junctions is completely set and a further verification of the electric junctions has been done with a tester.

In case you want to proceed to the excavation filling before the complete hardening of the epoxy, it is necessary to avoid covering the zones where the wells containing the string junctions or the terminals are present.



*These precautions are necessary since in case a wrong mixing of the two components is carried out, this epoxy may not grow tough. Therefore if after 24 hours the epoxy is not completely hard, you have to **cut** the junction or the terminal showing this problem and repeat the electric connections, the following verifications and carry out the treatment with epoxy again. The same problem can occur if after treating with epoxy the cables are under excessive physical or thermal stress which can compromise the electric connections. Therefore if during the last verification the electric connections show some problems, you have to **cut** the junction or the terminal in question and repeat the electric connections, the following verification and carry out the treatment with epoxy again.*

The filling up of the excavation is a very delicate operation which has to be carried out attentively and which follows different methods according to the type of surface (lawn, asphalt, stones or self-lockings).

In any case the sensors must be firstly all covered with dry sand or slightly wet so that the whole surface of the sensor can get in contact with it. In this way the vibrations in the ground can be picked up by the sensor whatever direction they come from in a very good way. In addition, the sand protects the sensor during the filling operations preventing it from being moved from its site or being damaged by the stones which can be present in the filling material.

The coverage of the excavation with mechanical means must be carried out with caution. A heavy wheeled vehicle can easily go deep in the trace of tilled ground damaging the sensor string.



*The closing of the excavation must be done with mechanic means on one side of the trace and must be followed by a compacting operation executed gradually to give lift to the tilled ground and to permit it to transmit the vibrations in a very good way.*

In the next paragraphs we will analyze the methods to close the excavation according to the following surfaces:

- Lawn surface;
- Ground covered with asphalt, with self-lockings or stones.

## 5.1 Lawn surface

In case of lawn surface, to close the excavation the taken off material can be used. The operative procedure is the following:

1. Cover the sensors with sand being careful that it adheres to the whole surface of the sensor without exceeding the quantity (a bucket of about 20~25 litres).

The sand helps avoiding the formation of air bubbles near the sensor and therefore favours the transmission of the seismic waves to the sensor. Be careful because an excessive quantity of sand cause an amortizing effect which could attenuate the seismic waves.

The sand also serves to protect the sensor from the possible presence of stones which could damage it during the excavation filling.

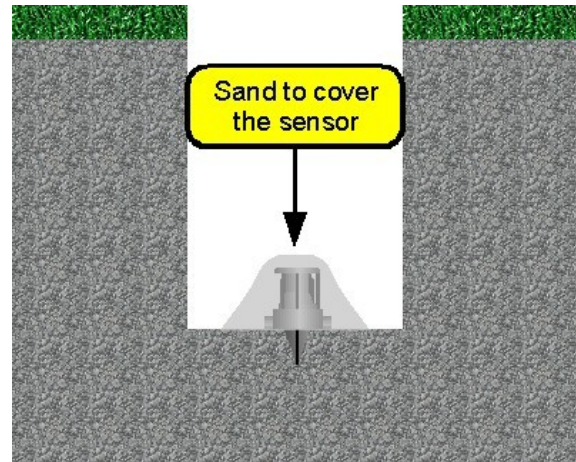

*In any case we suggest removing stones of big dimensions.*

2. Recover the hole softly, so as not to move the sensors from their site, with at least 20 cm of excavation ground up to 40 cm under the surface level.



*During this phase use the least impure ground, so as to create near the sensor a zone transmitting the seismic wave in a very good way.*

3. Make the excavation sides slide down, to obtain a band of tilled ground of at least 1.5 m, so as to obtain a homogeneous behaviour of the ground inside the detection cone of each sensor.
4. Fill up the excavation with the ground taken off deprived of stones of big dimensions.
5. Gradually compact the ground during the filling up.

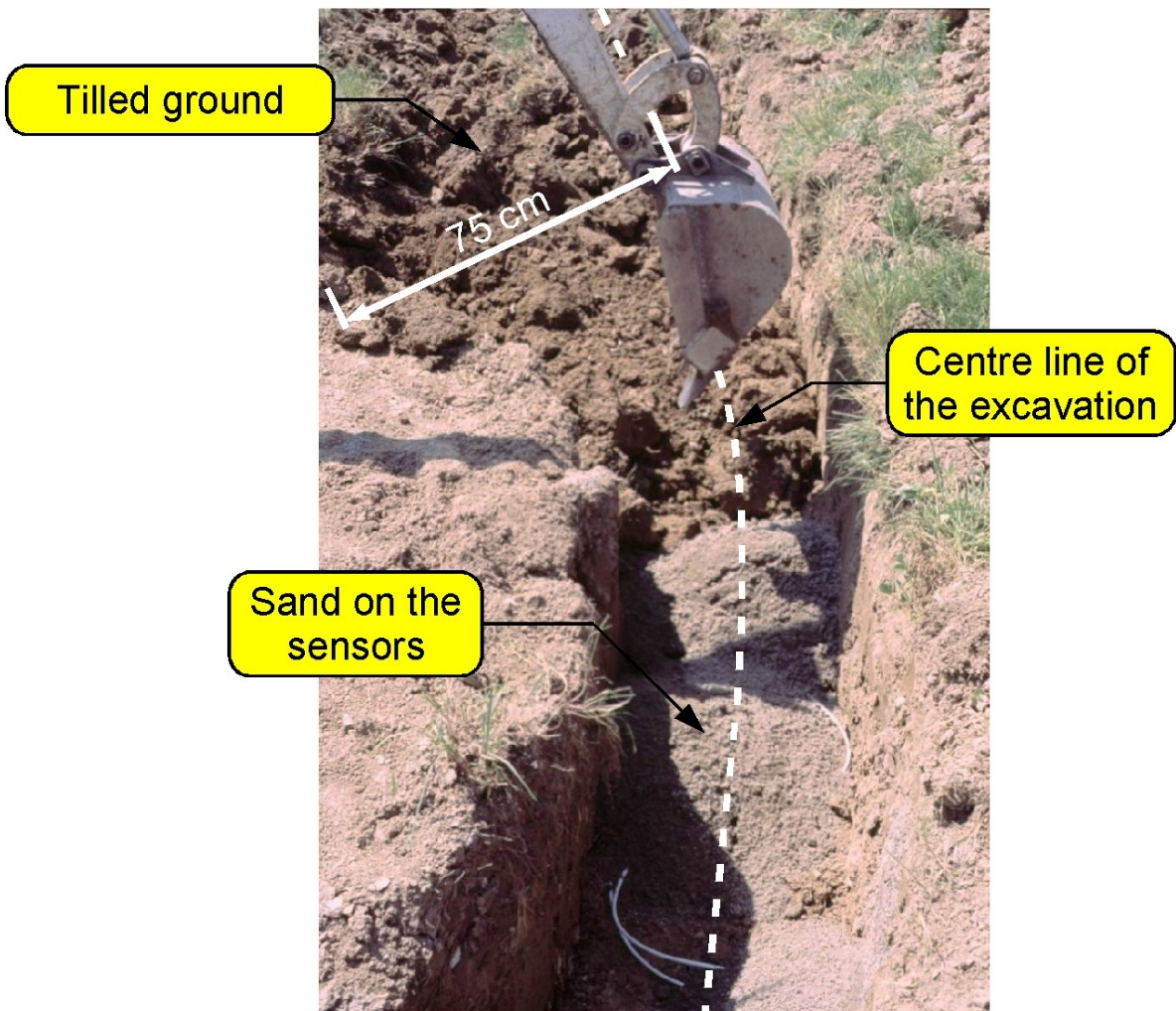

## 5.2 Ground covered with asphalt, self-lockings or stones

In case of ground covered with asphalt, with self-lockings or stones, it is not possible to use the material taken off, but it is necessary to recover the excavation with quarry stabilizer. The operative procedure is the following one:

1. Cover the sensors with sand by making it adhere to the whole surface of the sensor without exceeding the quantity (a bucket of 20~25 litres). The sand helps avoiding the formation of air bubbles near the sensor and therefore favours the transmission of the seismic waves of the sensor. Be careful because an excessive quantity of sand causes an amortizing effect that could attenuate the seismic waves. The sand also serves to protect the sensor from stones which could damage it during the excavation filling up.



*In any case we suggest removing the stones of big dimensions.*

2. Cover the cables of the string with sand. The quantity must be sufficient to protect them during the filling up.
3. Fill the excavation with quarry stabilizer, so that the ground becomes compact and transmits the seismic waves in a very good way.
4. Gradually compact the ground during the filling up.
5. Recover the ground with asphalt, self-lockings or stones.

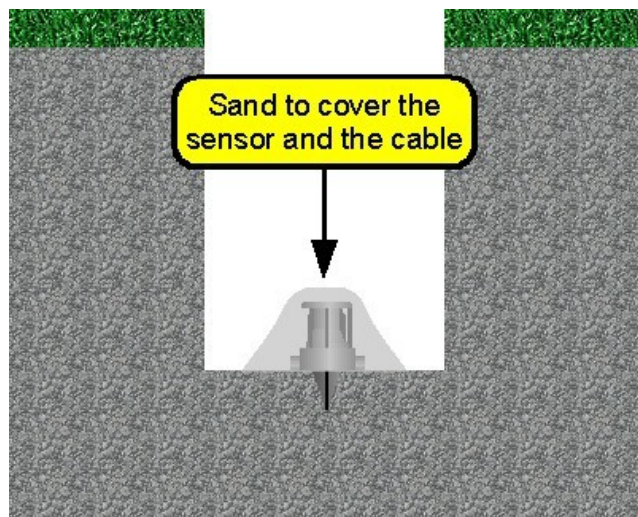

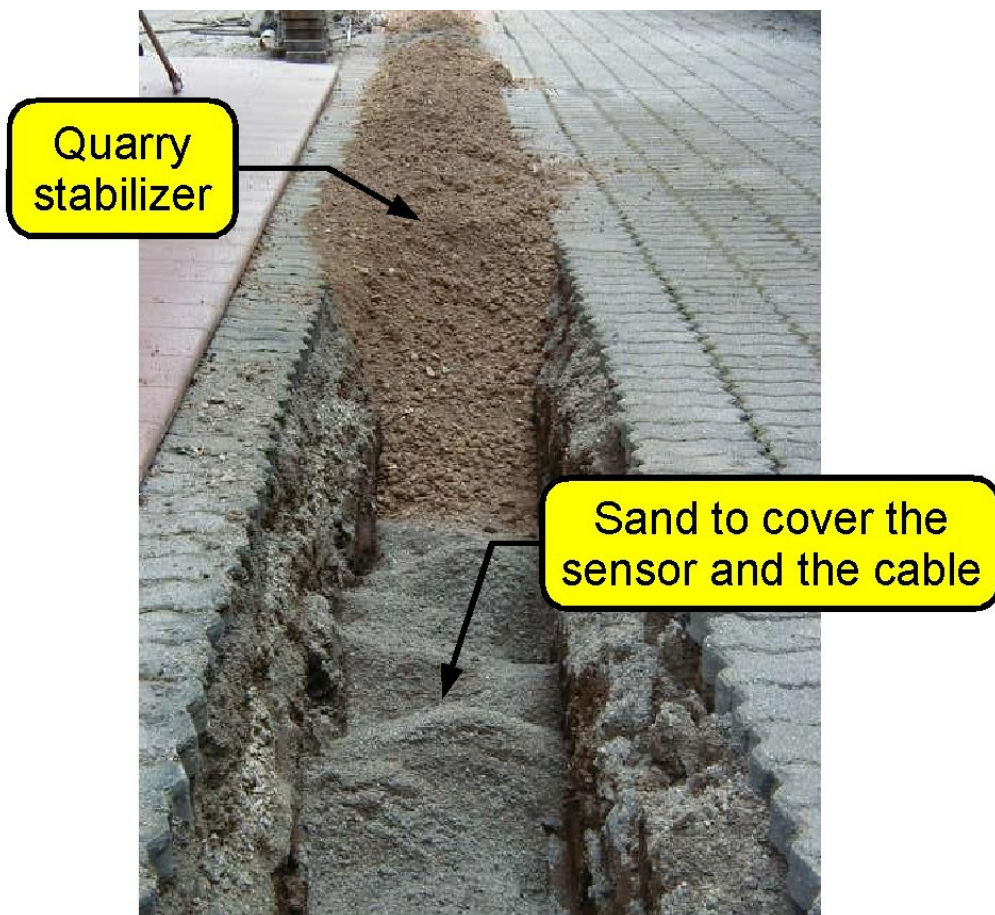
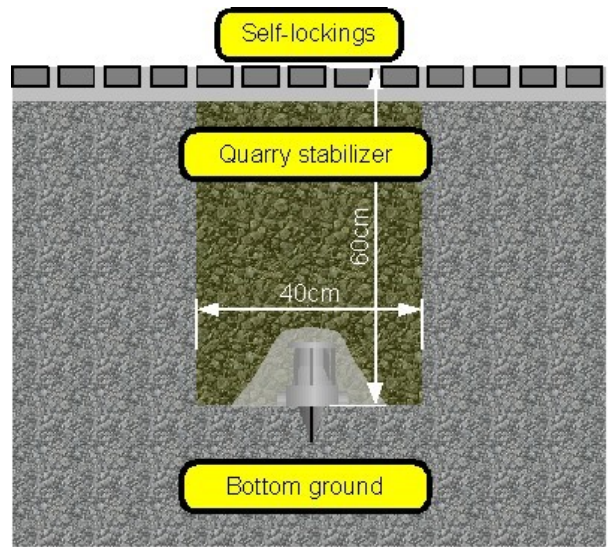
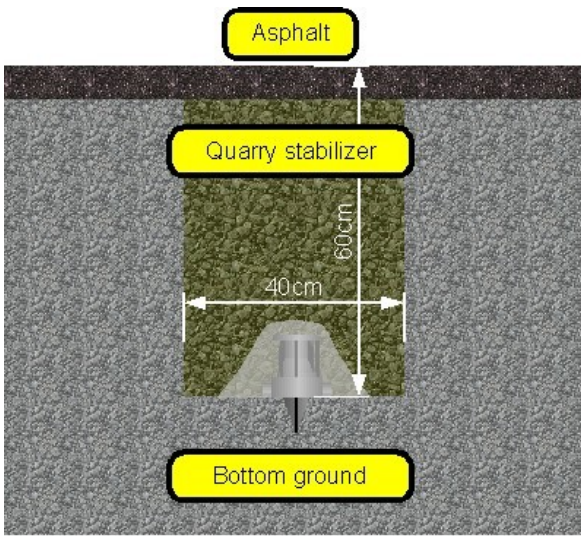

## 6 Electric connections of the processing board Z1

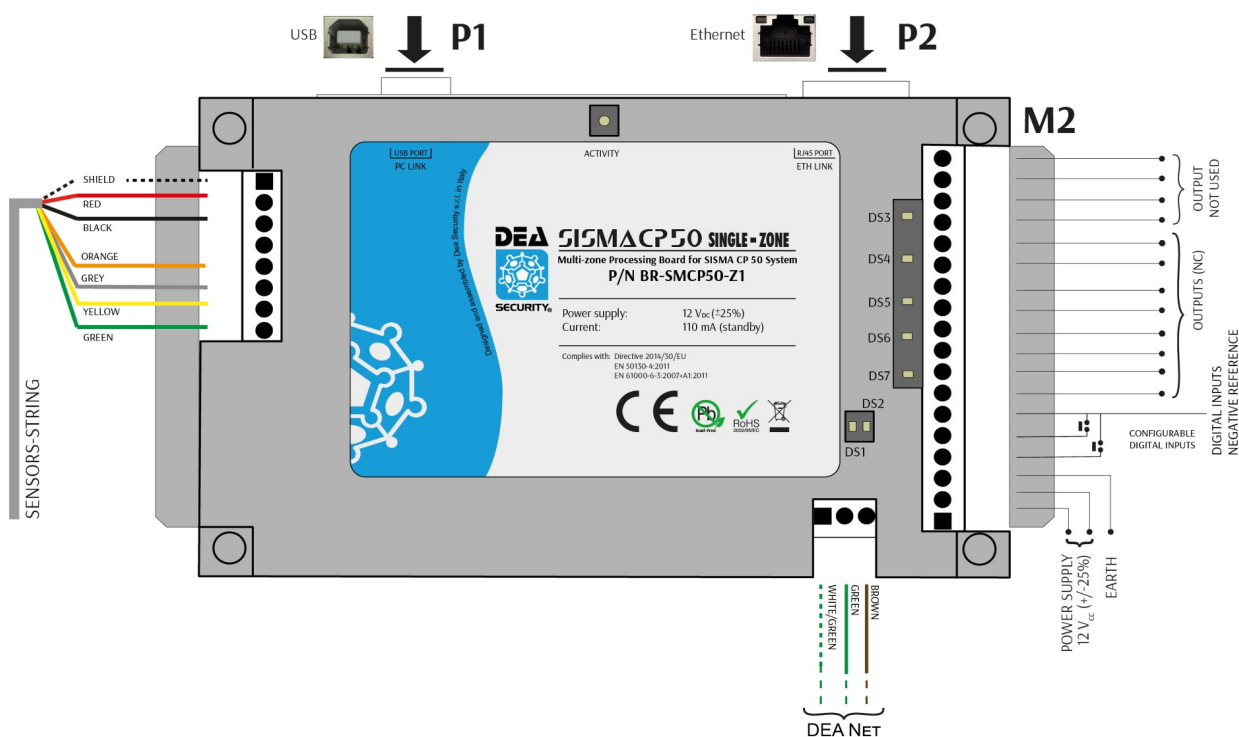

As regards the electric connections in the cabinet, you have to follow the diagram above (for more information please refer to BR-SMCP50-Z1 technical specifications).

- **SENSOR-STRINGS ( TERMINAL BLOCK M1)**

The sensor strings must be connected to M1 terminal block. Connect wire to S+ , black to S- and cable shield to SH of LINE 1A. Repeat the process for LINE 1B connecting orange wire to S+, grey to S-. Connect yellow wire to M1+ and green M1-. The maximum distance between the processing board and the first sensor of the string is 150 meters.

- **POWER SUPPLY & GROUNDING (TERMINAL BLOCK M2)**

The Board supply voltage is 12VDC, power failure condition is signaled opening MF relay and turning off led DS7 (in accordance with the positive security concept). The use of linear power supply unit is recommended such as AL-DN-DEAPW (alternatively AL25 or AL35). If the base plate of the peripheral cabinet containing the processing boards is made of insulating material or is not grounded, the metallic case of the board must be grounded directly. A standard yellow/green earth cable is provided.

- **INPUTS/OUTPUTS (TERMINAL BLOCK M2)**

The board has two configurable digital inputs (GND referenced) and outputs:

- MF (POWER FAIL) - Low supply voltage, service activity connected using software and no operative software present;

- OUT1 - Intrusion Alarm;
- OUT2 - Tamper Alarm;
- OUT3 - Prealarm;
- OUT4, OC 1 e 2 - not used
- DEA NET BUS (TERMINAL BLOCK M3)

The connection of the processing board to DEA NET communication network is made through M3 terminal block. If the board is the last on BUS DEA NET line, it is necessary to close the jumper JP1, to insert the end of line termination.

- PC-LINK (P1 PORT) - WAN/LAN CONNECTION (P2 PORT)

The following connection ports are available on the board:

- P1 port (USB type B) is used for service activities by means of a connected PC and a software supplied.
- P2 port (ethernet) is used for connecting SISMACP50 system to LAN/WAN network, using TCP/IP protocol, for the following applications:
  - DEA MAP supervision software integration;
  - third-party Video surveillance system integration (using Plugin);
  - third-party Software integration (using dynamic library SW-DM-DLL);
  - service Activity by means of a connected PC and a software supplied.

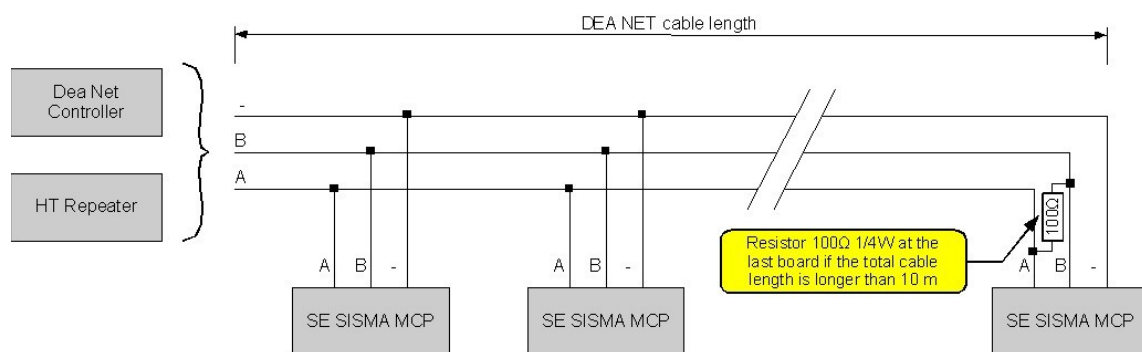

**Connection of the processing board to Dea Net**

## 7 Electric connections of the processing board Z2

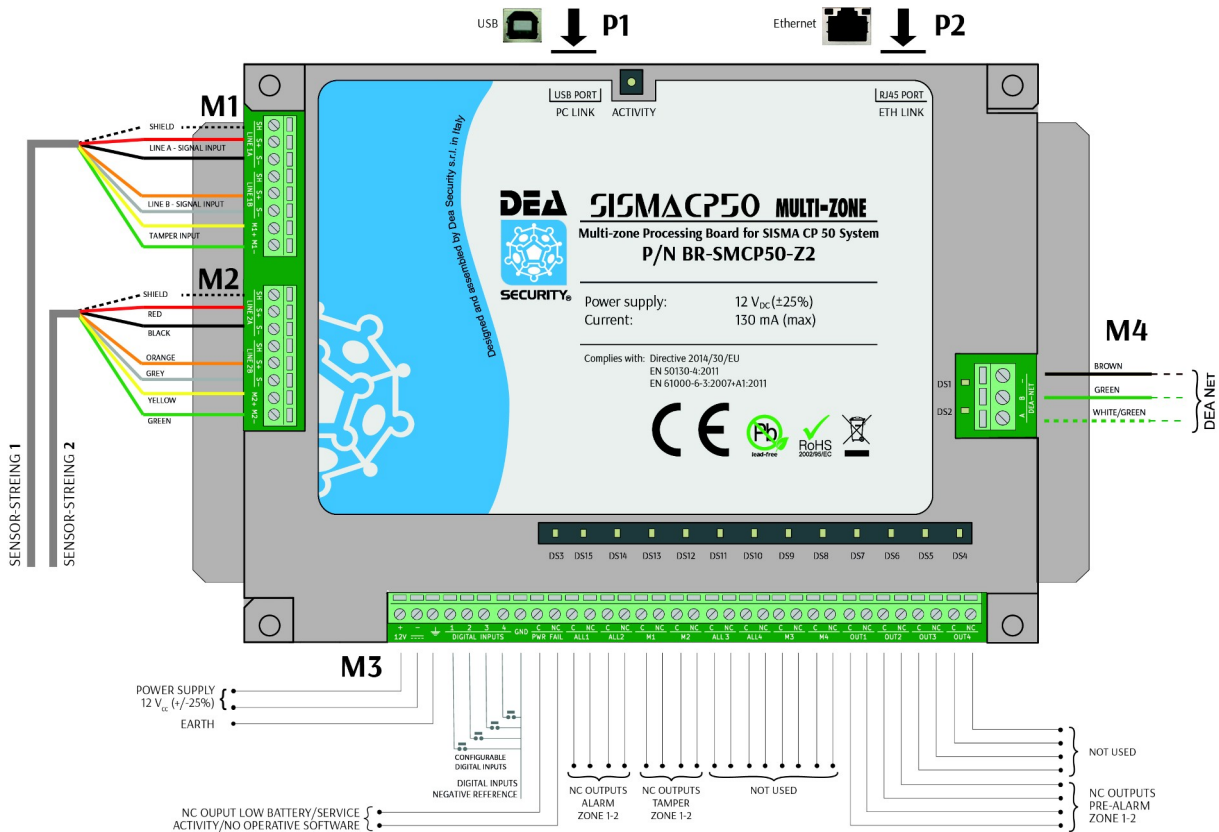

- **SENSOR-STRINGS ( TERMINAL BLOCK M1, M2)**

The sensor strings must be connected to M1 terminal block. Connect wire to S+ , black to S- and cable shield to SH of LINE 1A. Repeat the process for LINE 1B connecting orange wire to S+, grey to S-. Connect yellow wire to M1+ and green M1-. Make the same connection with the wires of the second string, The maximum distance between the processing board and the first sensor of the string is 150 meters.

- **POWER SUPPLY & GROUNDING (TERMINAL BLOCK M3)**

The Board supply voltage is 12VDC, power failure condition is signaled opening PWR FAIL relay and turning off led DS3 (in accordance with the positive security concept). The use of linear power supply unit is recommended such as AL-DN-DEAPW (alternatively AL25 or AL35).

If the base plate of the peripheral cabinet containing the processing boards is made of insulating material or is not grounded, the metallic case of the board must be grounded directly. A standard yellow/green earth cable is provided.

- **INPUTS/OUTPUTS (TERMINAL BLOCK M3)**

The board has 4 configurable digital inputs (GND referenced) and outputs:

- PWR FAIL - Low supply voltage, service activity (logged into the software) and no operative software uploaded;
- ALL1, ALL2 - Intrusion alarm (zone 1, zone 2);
- ALL3, ALL4 - not used;
- M1, M2 - Tamper alarm (zone 1, zone 2);
- M3, M4 - not used;
- OUT1, OUT2 - Prealarm (zone 1, zone 2);
- OUT3, OUT4 - not used;
- DEA NET BUS (TERMINAL BLOCK M4)

The connection of the processing board to DEA NET communication network is made through M4 terminal block. If the board is the last on BUS DEA NET line, it is necessary to close the jumper JP1, to insert the end of line termination.

- PC-LINK (P1 PORT) - WAN/LAN CONNECTION (P2 PORT)

The following connection ports are available on the board:

- P1 port (USB type B) is used for service activities by means of a connected PC and a software supplied.
- P2 port (ethernet) is used for connecting SISMACP50 system to LAN/WAN network, using TCP/IP protocol, for the following applications:
  - DEA MAP supervision software integration;
  - third-party Video surveillance system integration (using Plugin);
  - third-party Software integration (using dynamic library SW-DM-DLL);
  - service Activity by means of a connected PC and a software supplied.

## 8 Sensitivity calibration

To calibrate the sensitivity, please refer to *SISMA CP 50 software Manual*.

## 9 Perturbing elements and preventive actions

SISMA CP 50 detection system is sensitive to low frequency seismic waves, normally originated by a person's passage on the ground.

If near the protection line were present a source of seismic waves, as the one seen in paragraph 3.1 on page 4, this could generate improper alarms.



*If the security distances suggested are kept during the determination of the route, further protection actions are not necessary.*

If it were not possible to keep the security distances, the protection line would be exposed to improper vibrations. In these case it is necessary to create mechanical barriers which prevent the vibrations from reaching the sensors.

Hereinafter some of the solutions to the most common problems will be analyzed.

### 9.1 Plants or pilings

In the table in paragraph 3.1, you can see that the suggested distance between the protection line and a plant or a piling is about 3~4 metres.

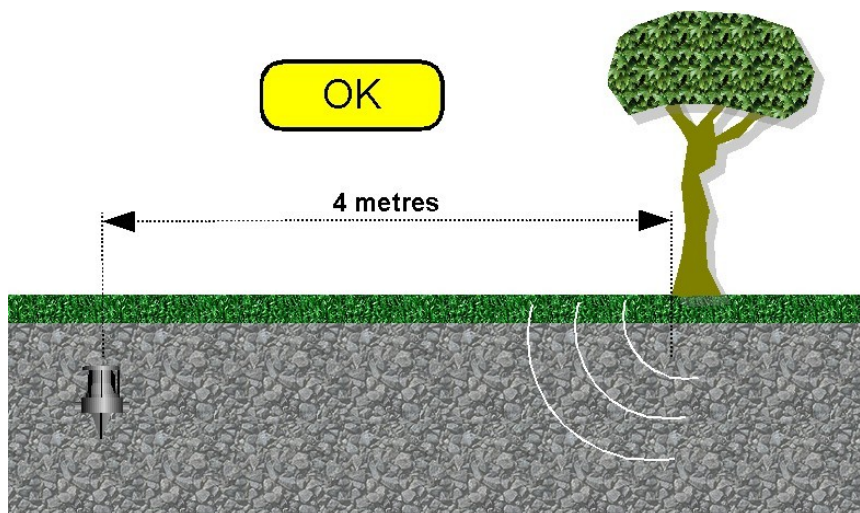

In case this distance cannot be kept, during the laying phase or at the occurrence of a possible disturbance, it is necessary to built an underground toe wall, which damps the vibrations coming from the plant or the post.



*In any case, even if a barrier is built, it is not possible to go under 2.5 m from the post or piling.*

The wall must be built at a distance of about 1 metre from the plant. For its construction, you have to proceed to the creation of an excavation 20 cm wide, 80 cm deep and parallel to the string. The length of the wall must be such that no vibration reaches the sensors nearer the minimum distance.

Locate the first sensors remaining at more than 3~4 metres from the plant and build an ideal triangle with the vertexes corresponding to the two located sensors plus the plant. Make the excavation for the construction of a wall so that it stretches out for some cms from the ideal triangle just built.

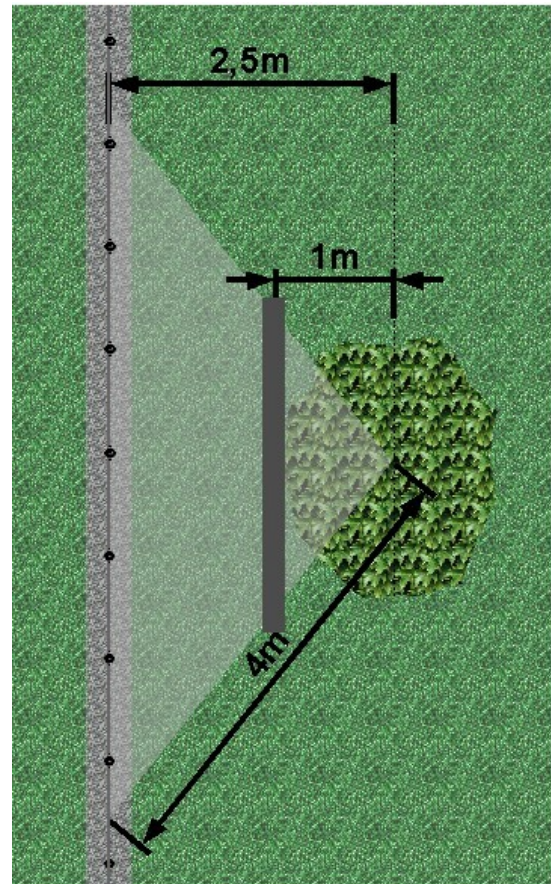
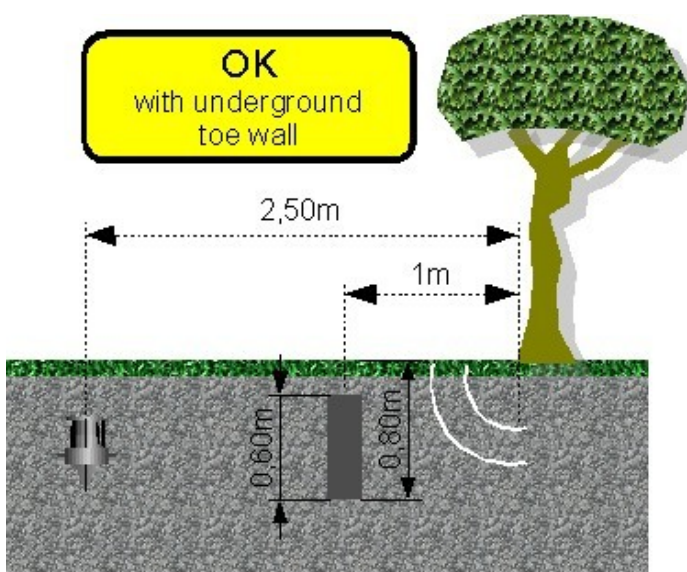

Once the excavation has been executed, insert an electrowelded net of the right size inside it, to reinforce the concrete; then cast the concrete directly inside the excavation, up to 20 cm from the surface level.

Once the concrete is dry, recover the remaining excavation to come back to the previous state of ground.

In case of narrow passages, it is necessary to realize a double wall among the plants. The double walls must be built with the same criteria seen for the single walls.

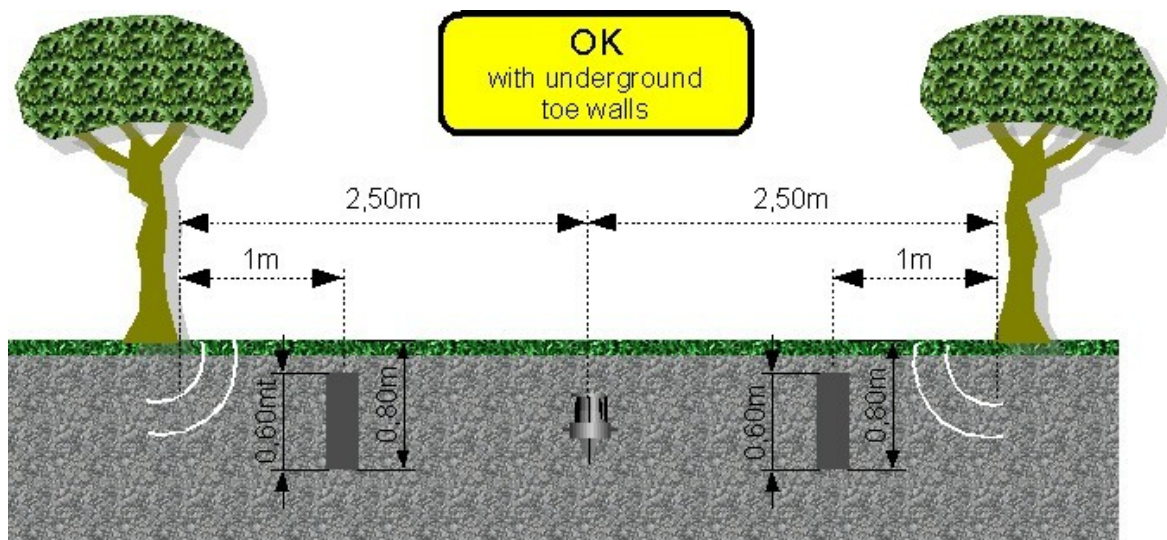

## 9.2 Roads and streets

A road is a source of seismic disturbances which can vary their entity according to the traffic passing through it. These disturbances can be intercepted by LN-SMCP50 strings set near the road. The intercepted depends from the following factors:

- Distance between the string and the road
- Type of ground
- Transit of heavy vehicles
- Presence of transversal factors.

Hereinafter we will analyze some solutions to make the disturbances decrease according to the factor you want to attenuate:

- *Distance between the string and the road.* To avoid seismic disturbances coming from the road, the security distance to be kept is about 5 m, provided that no heavy vehicle transits on it. If disturbances due to heavy vehicles occur, it is necessary to build a barrier to separate the string from the road.



*Contact DEA SECURITY to find the best solution to the problem.*

- *Type of ground.* According to the type of ground present between the road and the protection line, the transmission of seismic waves is more or less attenuated. In case of lawn soil, sandy or with filled ground, the vibrations are absorbed in a better way and their transmission is limited. In this case, there should be no problem of disturb-

ance propagating up to the protection line.

In case of beaten soil and covered with stabilizer, we deal with a ground which is not easy to be pressed and which hardly absorbs the vibrations even at a distance. It is therefore possible that even at the suggested minimum distance some disturbances reach the protection line; to avoid this inconvenience, it is necessary to build a barrier to separate the string from the road.



*To find the best solution to these problems, please call Dea Security.*

- **Heavy vehicles transit.** The transit of heavy vehicles at high speed provokes in the ground high intensity seismic waves, which could be picked up by the sensor strings even at more than 10 metres. In this case, it is necessary to built a barrier to separate the string from the road.



*To find the best solution to these problems, please call Dea Security.*

- **Presence of transversal vectors.** A rigid piping passing under a road in a transversal way favours the transmission of vibrations which arrive at the sensors in a very strong way. Examples of vibration vectors can be the sewer pipings, aqueduct pipings, drainage of waters and so on. In this case, besides keeping the security distances from the road, it is also necessary to keep 1 metre distance from rigid pipings. To find solutions to these problems, please refer to paragraph 9.4 on page 38. To find solutions to the presence of drain pipings, please refer to paragraph 9.6 on page 43.

## 9.3 Buildings

When buildings are present, it is necessary to keep from them a preventive distance of at least 5 m.

This is for a security reason, since by making the string pass too near a building, the last one would be avoided by simply leaning a ladder against the wall of the building.

An another reason why it is necessary to keep a distance of at least 5m, is that in case of strong wind may occur seismic noises in the ground intercept by SISMA CP 50 system sensors.

It is not possible to decrease the suggested distance through the construction of toe walls, since the size of a building is not comparable to one of a wall, which, therefore, couldn't dampen possible oscillations.

## 9.4 Irrigation, fire-fighting and aqueduct pipes

The sudden variations of pressure inside a pipe, known as ram stroke, generate seismic waves which can reach the sensors of SISMA CP 50 string. If these sensors are set at less than 1 metre from the pipe, they can gather this disturbance and originate improper alarms.

The pipes can be perpendicular to the string or parallel to it.

### 9.4.1 Pipes perpendicular to the string

When one or more than one pipe under pressure cross the protection line, it is necessary to attenuate the vibrations caused by the pipes themselves in the ground.

If only one pipe is present, it is possible to wrap it with material absorbing the vibrations. If more than one pipe is present, you have to proceed to the pipe insulation with a containing canal made of concrete, since the first technique is not applicable.

- *Pipe insulation.* The insulation must be executed by covering the pipe with another pipe at least 5 cm greater in diameter and by filling the gap between them with an insulating material, for example expanded polyethylene used as non-conducting in hydraulics, so that the pipes can be concentric. The pressure pipe must be wrapped for a length of about 1.50 m. The operative procedure is the following one:
  - Make a small excavation around the transversal pipe for a length of about 2 m.
  - Set the sensors at the same distance from the pipe.
  - Prevent the connection cable of the sensors from touching the pipe.
  - Wrap the pipe for a length of at least 1.5 m with material absorbing the vibrations, for example expanded polyethylene used in hydraulics for thermal insulation, with a layer of at least 2 or 3 cm.
  - Cover all of it with a pipe presenting a diameter which does not press too much on the spongy cover and which is not too loose.
  - Cast concrete on the whole thing, so that the remaining vibrations can be attenuated.

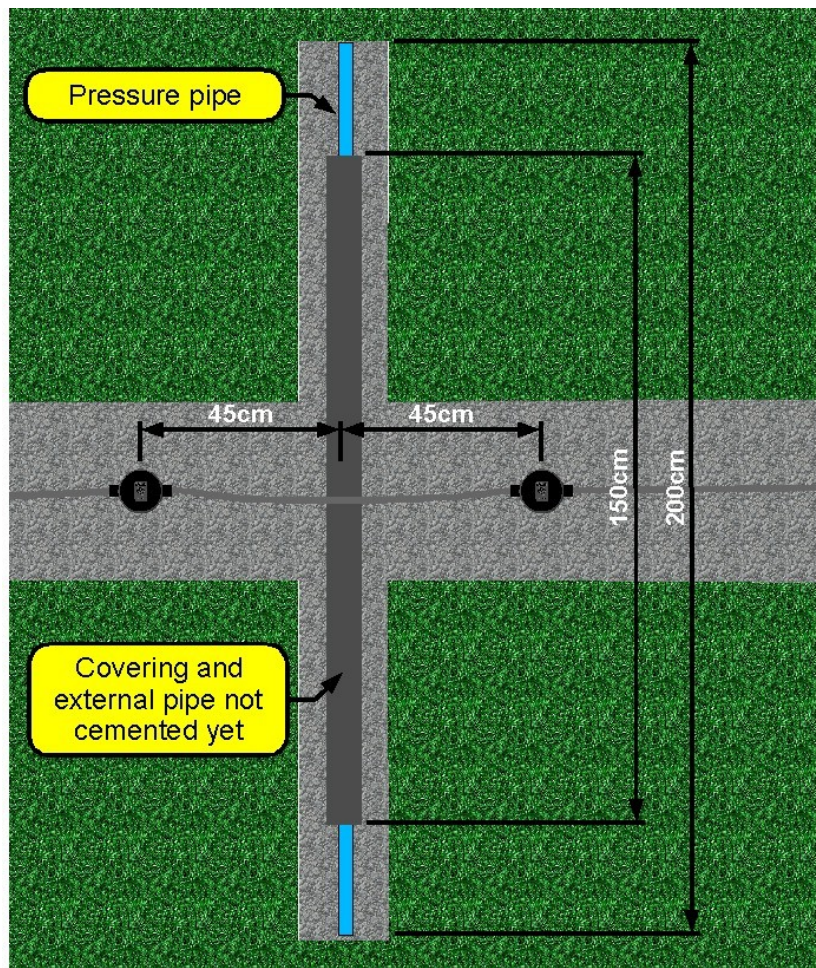
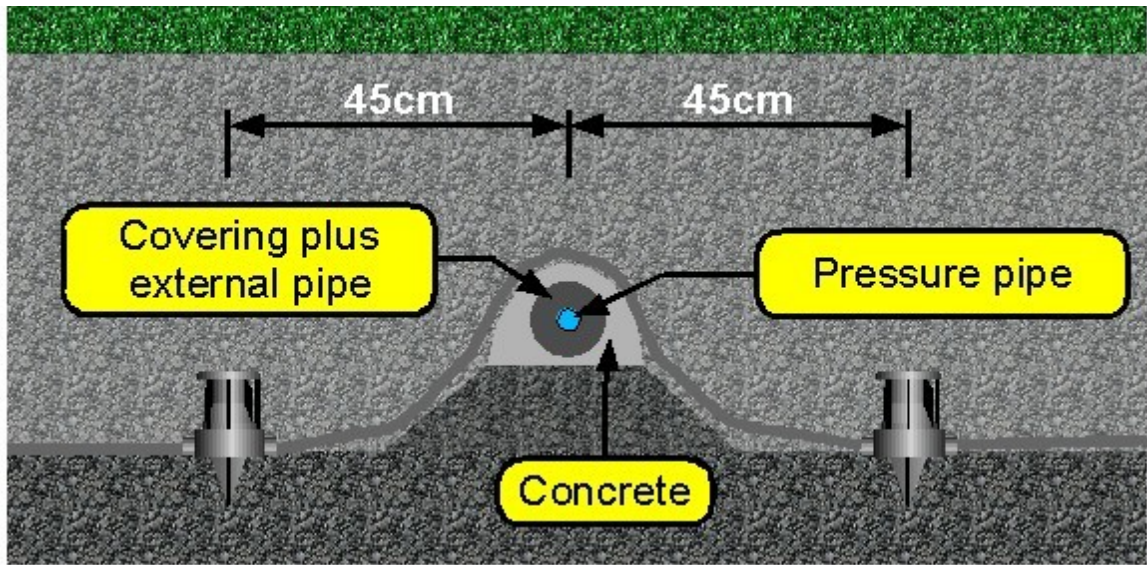

- Insulation of more than one pipe. Since the first solution is not applicable, it is possible to embed the pipes inside a concrete canal of adequate dimensions and fill it with sand so that the vibrations can be softened. In this case also the rigid concrete walls cause a reduction of the vibrations.

The procedure is the following one:

- Carry out an excavation of adequate width and at least 2 m long where the concrete canal must be laid.
- Set the concrete canal in a position that permits containing the pipes to be insulated without their touching the walls, otherwise the vibrations would be transmitted all the same.
- Position both of the sensors at an equal distance (minimum 30 cm) from the well.
- Prevent the connection cables of the sensors from touching the concrete walls..
- Fill up the well with sand.

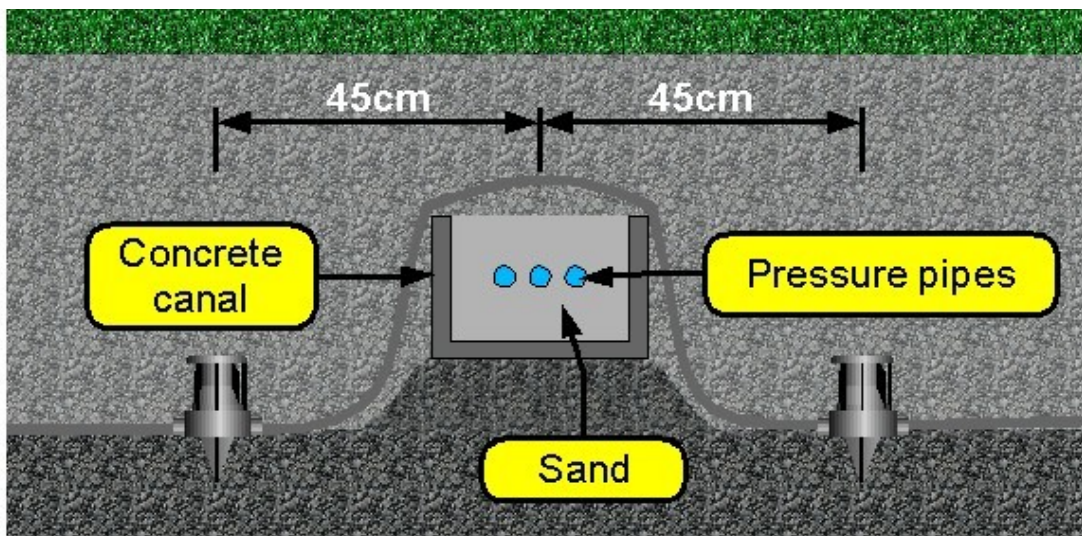

## 9.4.2 Pipe parallel to the string

In case the protection line is situated at less than 1 metre from pressure pipes, it is necessary to shield the disturbances coming from the pipings with a barrier.



*It is not possible to shield pipes passing at less than 50 cm.*

The barrier must be built as near as possible the pipe and must have a depth of up to 80 cm. In addition, it must be 20 cm wide and 60 cm high.

The operative procedure is the following one:

1. Make an excavation of 20 cm wide, as near as possible the pipe, and long enough for the pipe shielding. Its depth will have to be of 80 cm.
2. Once the excavation has been executed, insert an electrowelded net of the right size inside it.
3. Cast the concrete directly inside the hole just excavated, up to 20 cm under the ground level.
4. Once the concrete is dry, cover and restore the previous state of the surface.

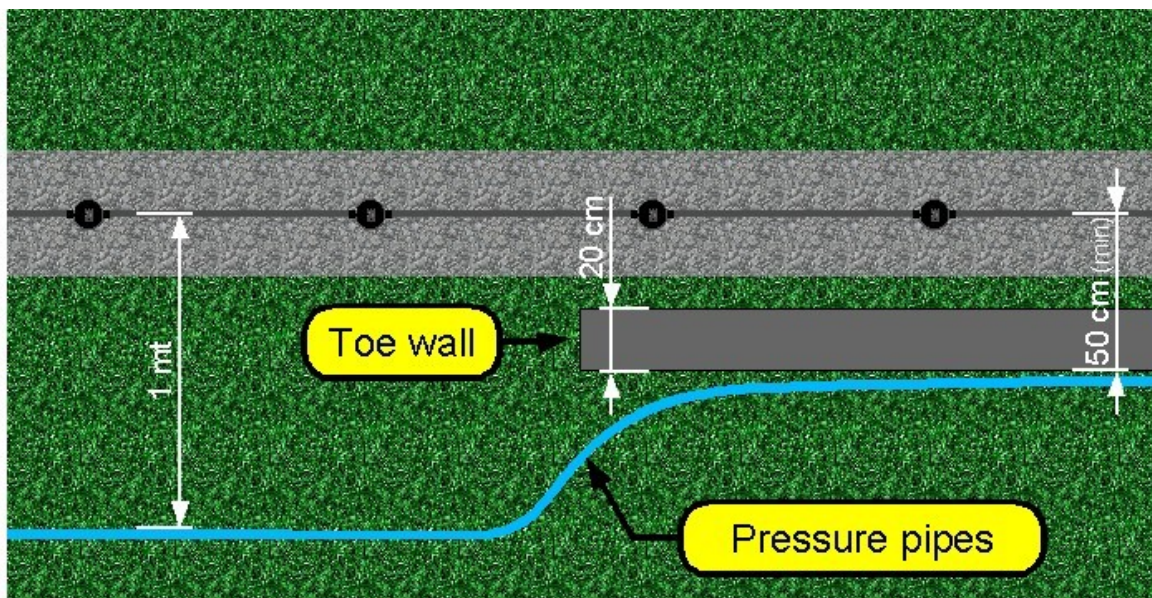

## 9.5 Pumps

The activation of a pump provokes vibrations in the surrounding ground which can be intercepted by the sensors of SISMA CP 50 system. For this reason it is necessary to keep the protection line at a security distance of at least 2 metres from the pump.

In case it is not possible to keep this distance, the interferences can be reduced with the construction of a toe wall as near as possible the pump.

The wall will have to be 80 cm deep and minimum 20 cm wide. Its height will be of 60 cm and its length such that it must permit the sensors to stay 2 m minimum from the pump.



*In any case, even by building a barrier, it is not possible to pass at less than 1 metre from the pump.*

The operative procedure is the following one:

1. Create an excavation 20 cm wide and 80 cm deep, as near as possible the pump. The length of the excavation has to be such that it must permit the sensors to stay at at least 2 metres from the pump.
2. Once the excavation has been carried out, insert an electrowelded net of the right size inside it.
3. Cast the concrete directly inside the hole just excavated, up to 20 cm under the ground level.
4. Once the concrete is dry, cover and restore the previous state of the surface.

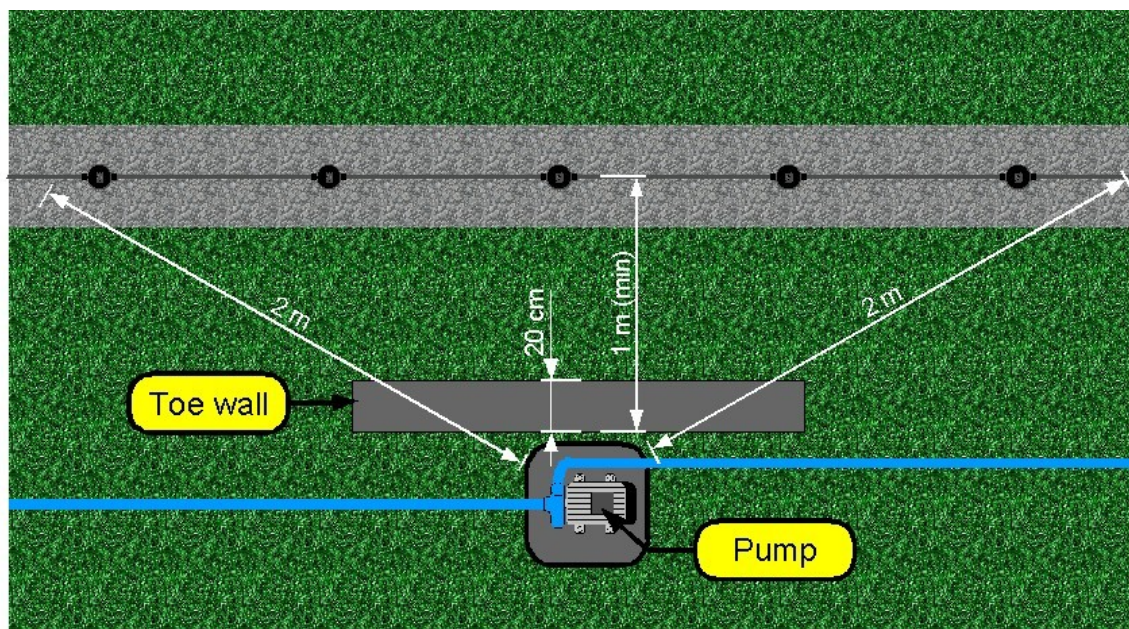

## 9.6 Drain trunk-line

A big pipe of concrete, used as drain trunk-line which crosses the protection line, in some cases can represent a vehicle of disturbances. If for example the piping passes under a road, the passage of big vehicles can cause vibrations which, through the pipe, can arrive far away and be perceived by the sensors even if they are set at a security distance. The cases that can occur are two :

- The pipe passes under the road;
- The pipe does not pass under the road;

Let us analyze the above situations:

- *The piping passes under the road.* In this case it is necessary to keep the sensors at 1 metre minimum from the piping. It is therefore possible that a zone non covered by SISMA CP sensors forms on the surface. The size of this area includes a band of 50 cm before and behind the pipe, besides the whole width of the pipe. Take into consideration the possibility of using other Dea Security systems, as SISMA CA system to be set on the uncovered area.

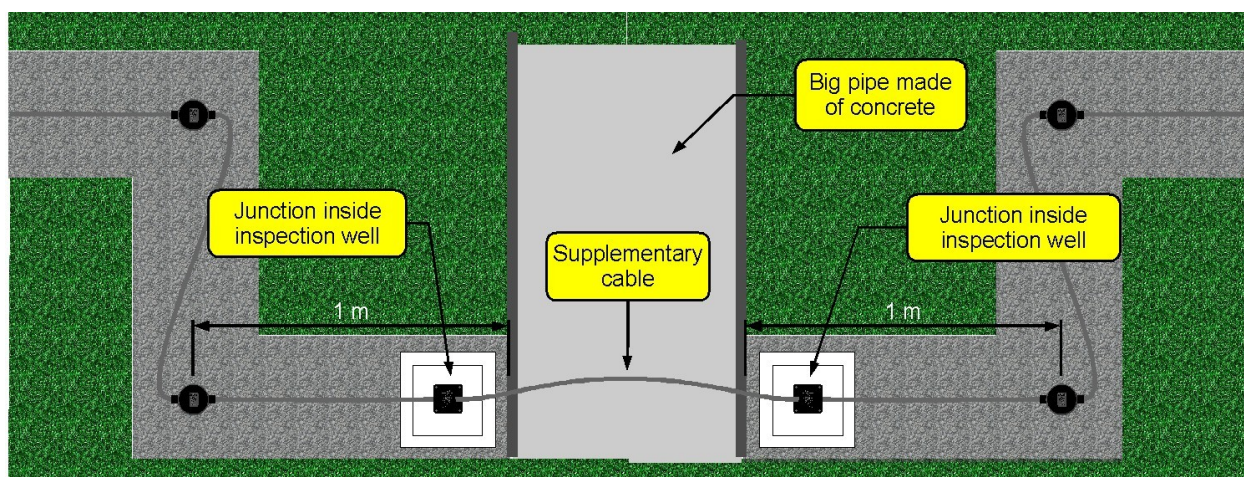
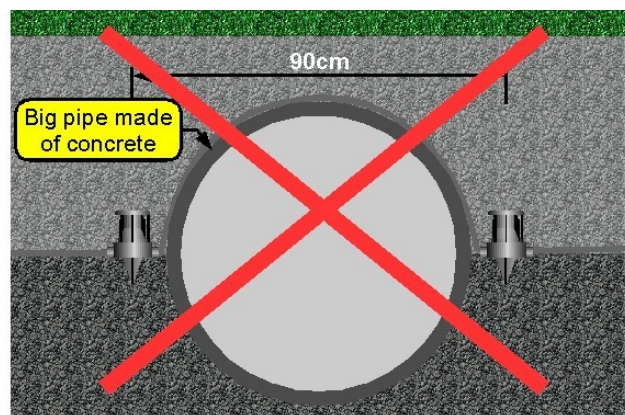

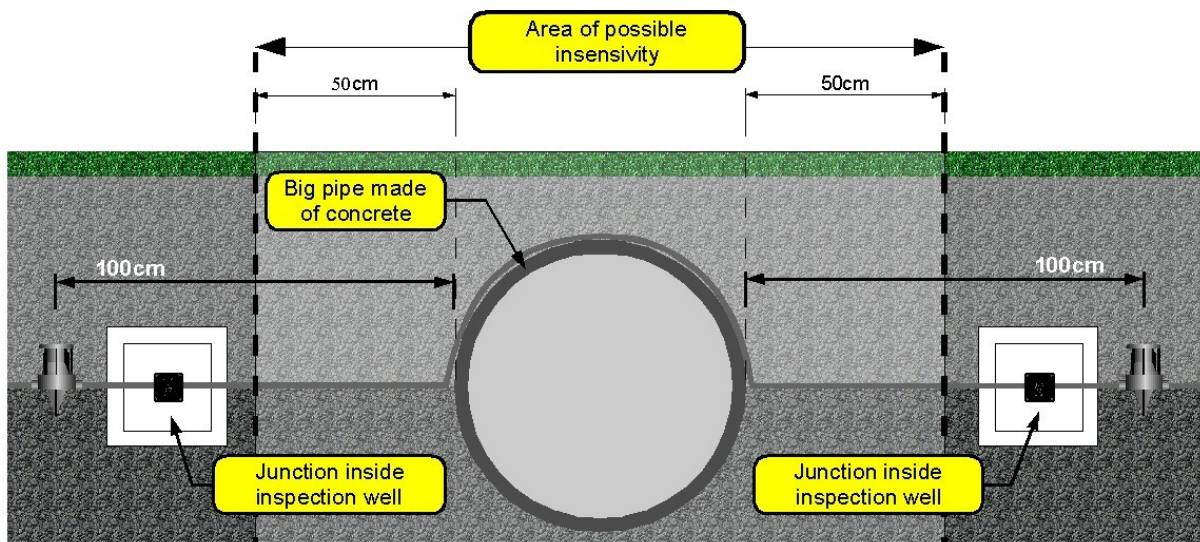

- *The piping does not pass under the road.* In this case it is necessary to keep the sensors at a distance of minimum 30 cm from the pipe and prevent the connection cable from touching the wall of the pipe. To do this, it is necessary to cover the pipe of sand for 4~5 cm.

A zone non covered by SISMA CP 50 sensors can sometimes form on the surface. The size of this area includes a band which is about 40 cm narrower than the diameter of the concrete pipe. If the pipe has a diameter of less than 40 cm, no insensitive band occur. Take into consideration the possibility of using other Dea Security's systems, as SISMA CA system, to be positioned on the area which is remained uncovered. The operative procedure is the following one:

1. Cut the connection cables in half between two sensors.
2. Position the sensors at minimum 30 cm from the piping.
3. Execute the junctions (as explained in paragraph 4.6.1 on page 22) with a supplementary connection cable long enough to set the two junctions inside inspection-able wells.
4. Cover the pipe with sand for about 4~5 cm.
5. Lay the cable just connected on the sand, preventing it from touching the wall of the pipe.

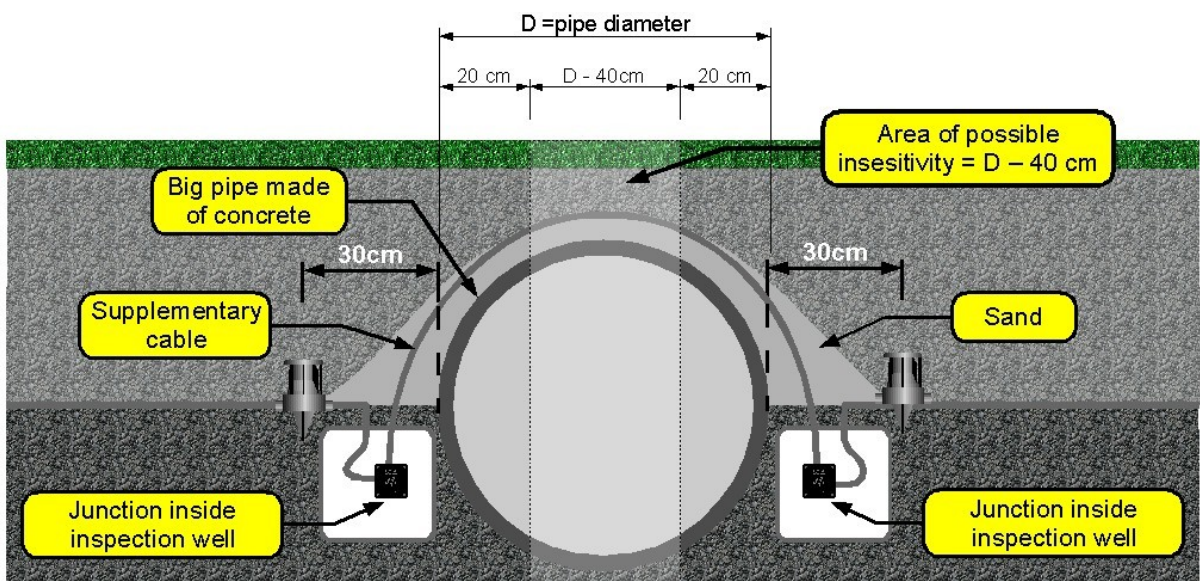
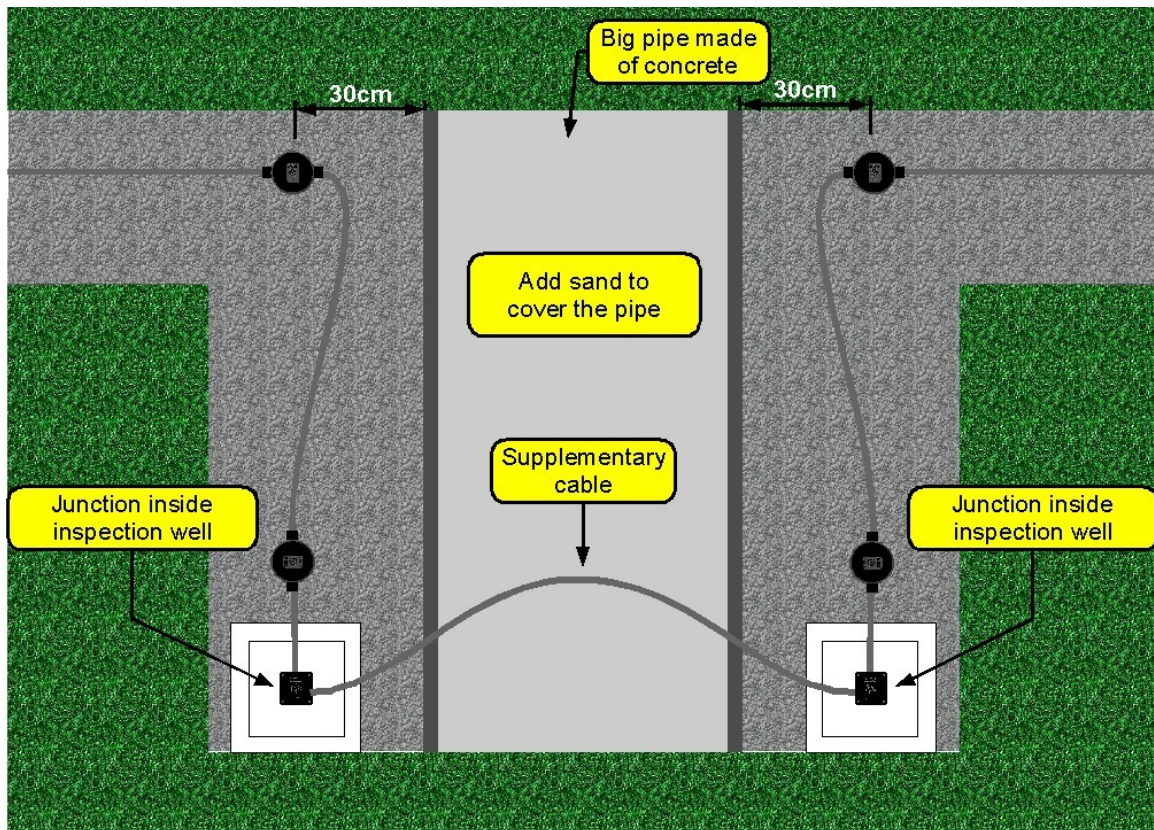

## 9.7 Unstable structures

The unstable structures are structures that can swing under strong wind and transmit their movement to the ground they lay on. Examples of unstable structures can be: huts without foundation in which tools are replaced, small penthouses, wings and so on.

The protection line must pass at 2 m minimum from the nearest support base. This distance varies according to the height and the consistency of the structure in question. In case it is not possible to keep more than 2 m or if a disturbance due to the aforesaid cause occurs, it is necessary to build a barrier which attenuates these disturbances. This barrier is composed of a wall at 80 cm of depth, 20 cm wide and 60 cm high and of a length such that the nearest sensor stays at 2 m minimum. The wall must be built at 50 cm from the support base of the unstable structure.

The operative procedure is the following one:

1. Create an excavation 20 cm wide, as near as possible the base of the structure, and long enough that the nearest sensor is situated at 2 m minimum. Its depth must be of 80 cm.
2. Once the excavation has been executed, insert an electrowelded net of the right size inside it.
3. Cast the concrete directly inside the hole just made, up to 20 cm under the ground level.
4. Once the concrete is dry, recover and restore the previous state of the surface.

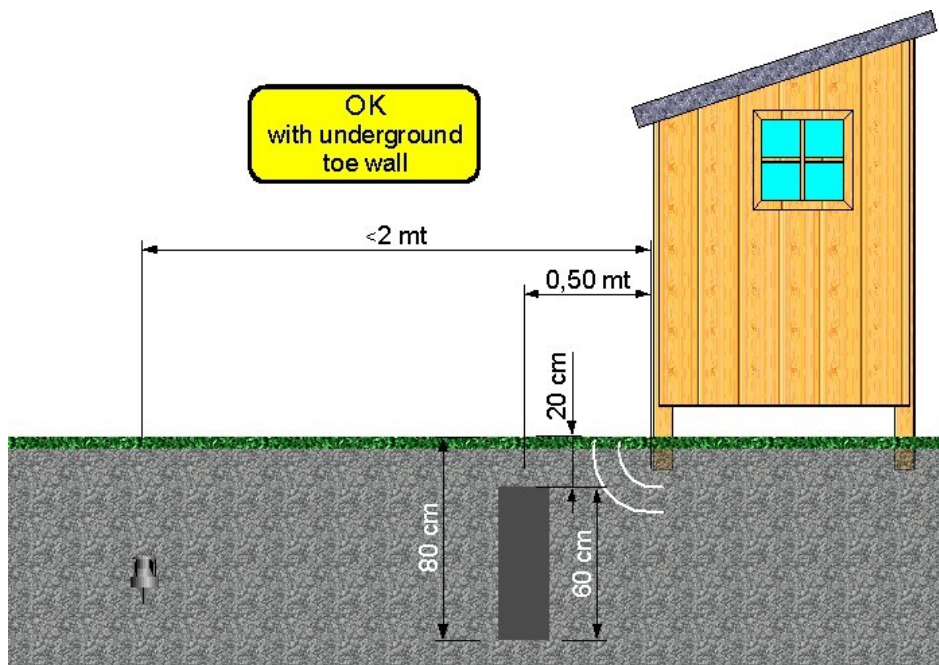

## 10 Maintenance

SISMA CP sensor strings do not need any type of maintenance.

The processing board, as all the electronic devices, can be subject to breakdowns, therefore it needs periodical verifications of functioning.

## 11 Assistance

DEA Security Service Department is at disposal for advice and technical service at:

Via Bolano, snc - 19037 Santo Stefano di Magra (SP) - tel. +39 0187 699233 - fax +39 0187 697615

Email: [dea@deasecurity.com](mailto:dea@deasecurity.com)

Web site: [www.deasecurity.com](http://www.deasecurity.com)

## Analitic index

<b>A</b>		
Alarm sector.....	9	
Alarm zone.....	4	
Assistance.....	48	
<b>B</b>		
Beginning of the string.....	12	
<b>C</b>		
Calculated lengths verification.....	16	
Canalizations.....	14	
Control panel.....	10	
<b>D</b>		
Drain trunk-line.....		
does not pass under the road.....	45	
passes under the road.....	44	
<b>E</b>		
End of the string.....	12	
Excavating machine.....	13	
Excavation.....		
Ground covered with self-lockings or asphalt.....	15	
Ground with lawn surface.....	15	
Excavation closing.....		
asphalt, self-lockings or stones.....	29	
Lawn surface.....	27	
<b>F</b>		
Following strings junction.....		
on different types of surface.....	13	
on the same type of surface.....	12	
<b>I</b>		
Initial string junction.....	23	
Inspection on the spot.....	4	
Intermediate String.....	24	
<b>M</b>		
Maintenance.....	48	
<b>P</b>		
Peripheral cabinets.....	10	
Pilings.....	35	
Pipes ,irrigation, fire-fighting and aqueduct....		
parallel.....	42	
perpendicular.....	39	
Plants.....	35	
Preventive actions.....	35	
Protection line.....	4	
Pumps.....	43	
<b>R</b>		
Roads and streets.....	37	
<b>S</b>		
Sand.....	14	
Sensor laying into the excavation.....	18	
String length.....	7	
Strings division.....	7	
Suggested distances.....	5	
<b>T</b>		
Table of distance.....	5	
Type of ground.....	7	
<b>U</b>		
Unstable structures.....	47	
<b>W</b>		
Wells.....	14	



Copyright© DEA SECURITY® 2022

Dea Security reserves the right to vary, at any moment and without notice, the technical features herein.

---

**DEA SECURITY S.r.l**  
Via Bolano, snc - 19037 Santo Stefano di Magra (SP) tel. +39 0187 699233 - fax +39 0187 697615  
VAT NO.: IT00291080455  
www.deasecurity.com - dea@deasecurity.com